



**CRUISER
AIRCRAFT**

No.: SB-CR-042

Date: 2018-05-14

Page: 1 of 14

SERVICE BULLETIN

Czech Aircraft Group s.r.o.
Na Záhonech 212,
686 04 Kunovice
Czech Republic
info@cruiseraircraft.cz

Rev.: 3

Date: 2020-09-14

MODEL AFFECTED:	PS-28 Cruiser and SportCruiser / PiperSport aircraft under EASA regulation
SUBJECT:	Landing Light Replacement (original TrailTech 4213-SX for TrailTech D112-SX)
AIRCRAFT AFFECTED:	All aircraft according to section "MODEL AFFECTED", as applicable
COMPLIANCE:	Apply this Service Bulletin when replacement of the original Trail Tech 4213-SX landing light is needed

DESCRIPTION:

This Service Bulletin contains instructions for replacement of the original landing light Trail Tech 4213-SX (hereinafter also referred to as the "Original landing light") by the new Trail Tech D112-SX landing light (hereinafter also referred to as the "New landing light"). The action also requires replacement of circuit breaker / switch circuit breaker with current rating of 3A.

APPROVAL:

Installation of the TrailTech D112-SX landing light has been approved by EASA under the Minor Change Approval No.10065161, dated 06 April 2018.

AUTHORISATION TO PERFORM:

EASA Part M or Part 145 Maintenance organization

REASON:

Production of the Original landing light was terminated by the manufacturer. The New landing light represents fully equivalent and approved replacement.

MANPOWER:

Approximately 10 working hours.

SPECIAL TOOLS:

Common maintenance tools for aircraft servicing (imperial and metric size tools, as well). Wrench ½ inch.

WEIGHT AND BALANCE:

Insignificant effect.

ELECTRICAL LOAD DATA:

Not affected. Direct current required is approximately 0,5 Amps (i.e. by 2,2 Amps less than for the Original landing light)

REFERENCES:

N/A

 CRUISER AIRCRAFT	<h1>SERVICE BULLETIN</h1>	Czech Aircraft Group s.r.o. Na Záhonech 212, 686 04 Kunovice Czech Republic info@cruiseraircraft.cz
No.: SB-CR-042		Rev.: 3
Date: 2018-05-14		Date: 2020-09-14
Page: 2 of 14		

PUBLICATIONS AFFECTED:

PS-28 Cruiser Wiring Manual, CR-WMA-1-0-01, Rev.10 (Dynon).
PS-28 Cruiser Wiring Manual, CR-WMA-1-0-03, Rev.10 (SkyView).
PS-28 Cruiser Wiring Manual, CR-WMA-1-0-04, Rev.10 (Analog).
Supplement No.2 of POH

MATERIAL:

The New landing light kit and the circuit breaker MS3320-3 or the switch circuit breaker W31-X2M1G-3 (both current range of 3A) can be ordered as an assembly kit from the aircraft manufacturer.

COSTS:

To be covered by the aircraft owner / operator.

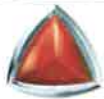
**CRUISER
AIRCRAFT**

SERVICE BULLETIN

Czech Aircraft Group s.r.o.
Na Záhonech 212,
686 04 Kunovice
Czech Republic
info@cruiseraircraft.cz

No.: SB-CR-042

Date: 2018-05-14

Page: 3 of 14

Rev.: 3

Date: 2020-09-14

ACCOMPLISHMENT INSTRUCTIONS:

1 Trail Tech landing light replacement

NOTE: Numbering of parts used in this Section 1 belongs to the Figures 1 to 4 below.

Legend to the figures 1 to 4 below:

ITEM	NAME	DRAWING / NOMENCLATURE
1	Original landing light Trail Tech 4213-SX	6902L113
2	Light console	
3	Bolt	
4	Self-locking nut	
5	Washer	
6, 7	Connector cover	
8	Female connector	
9	Male connector	
10	Wire (black, white)	
-		
12	Castle nut	
13	Cotter pin origin	
13	Cotter pin new – AN380-3-3	3231A303
20	Bolt - AN4-10A	3111A410
21	Bracket Top	SI0491N
22	Bolt – Hexagon Socket head DIN7984-M5x24-ZB	3111X525
23	New landing light Trail Tech D112-SX	6902L114
24	Male connector	Component D112-SX
25	Washer - Flat DIN125-5,3-ZB	3131X502
26	Nut - Self Locking DIN985-M5-ZB	3121X409
27	Eye Bolt Pressed	SI0495N
28	Nut - Thin DIN439-M6-ZB (2 pcs)	3121X605
29	Bracket Bottom	SI0492N
30	Rubber 7851, 63x20, thickness 1	511K0009
31	Nut - Self Locking AN365-428	3121B654
32, 33	Washer Flat AN960-416	3131A416
34	Washer Single Tab 5,3 DIN93-A2 (for elimination of gap between the New landing light mounting (23) and the threaded Eye Bolt (27))	3131X507
35	Washer Serrated 5,3-DIN6798A-ZB	3131X501



SERVICE BULLETIN

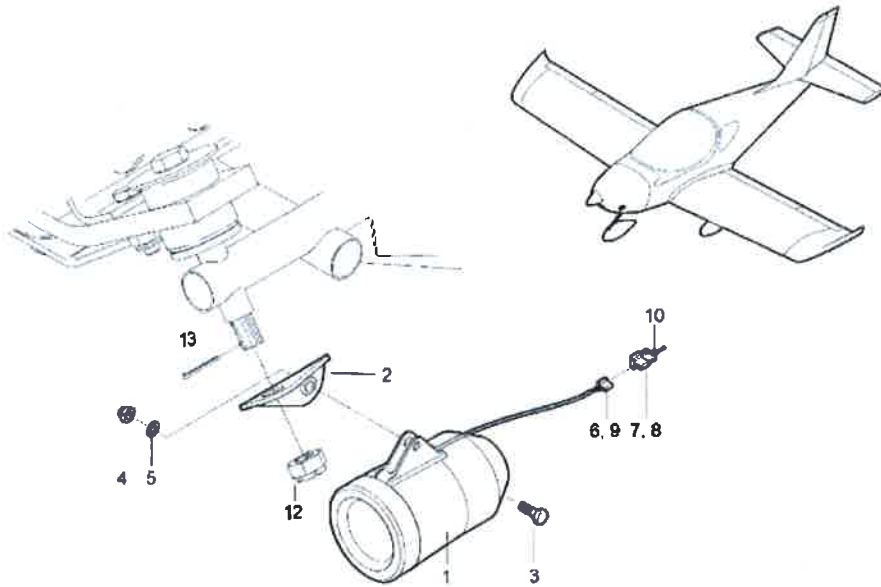

Figure 1 – Dismounting of the Original landing light Trail Tech 4213-SX

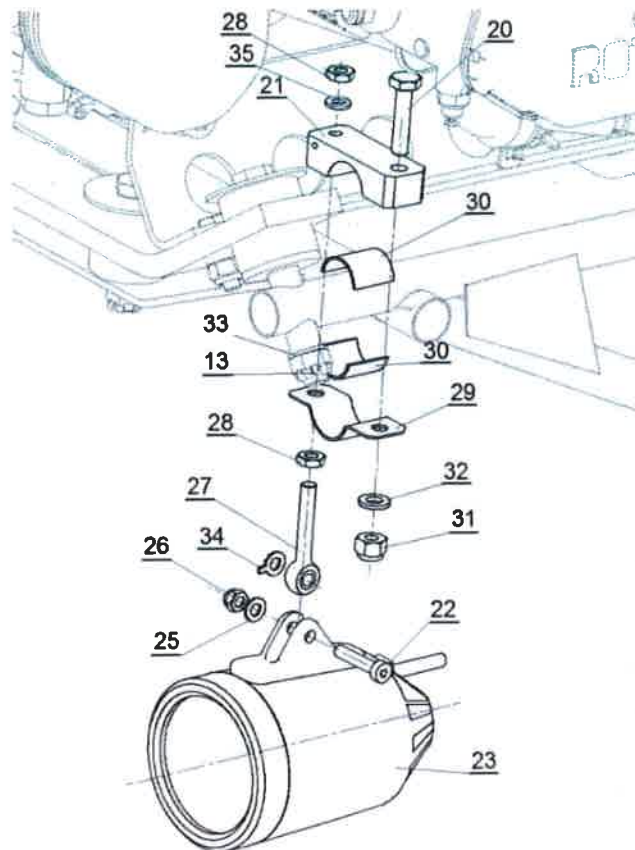

Figure 2 - Mounting of the New landing light Trail Tech D112-SX



SERVICE BULLETIN

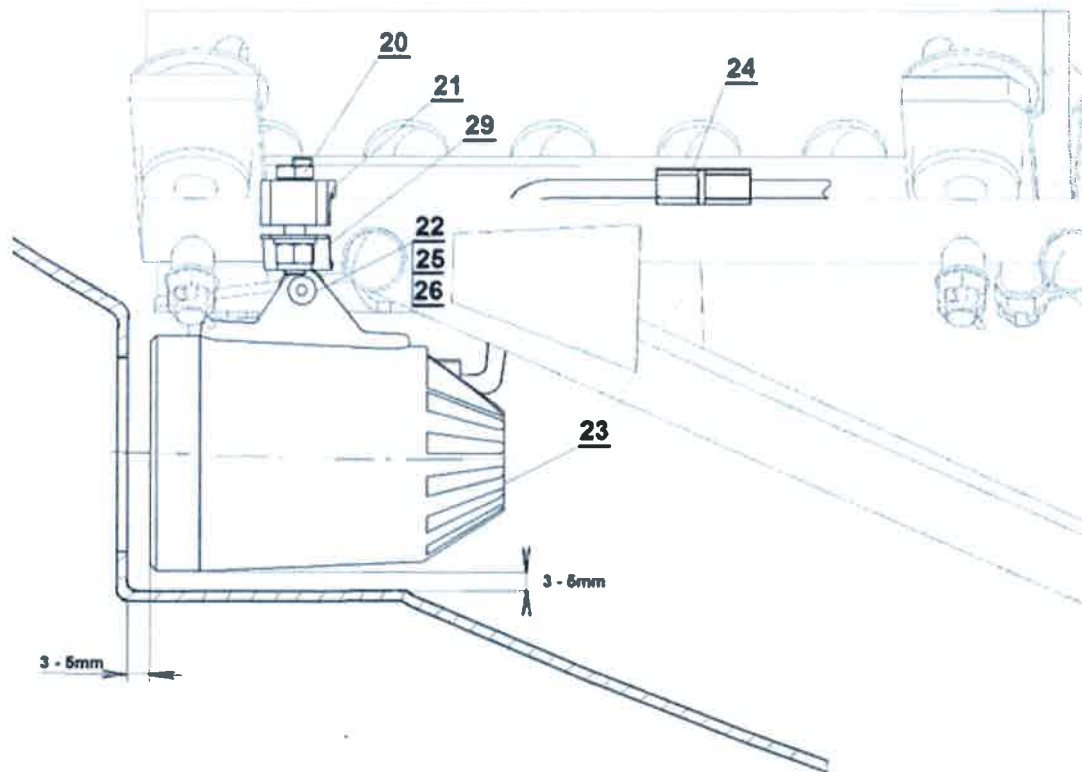

Figure 3 – The New landing light position adjustment

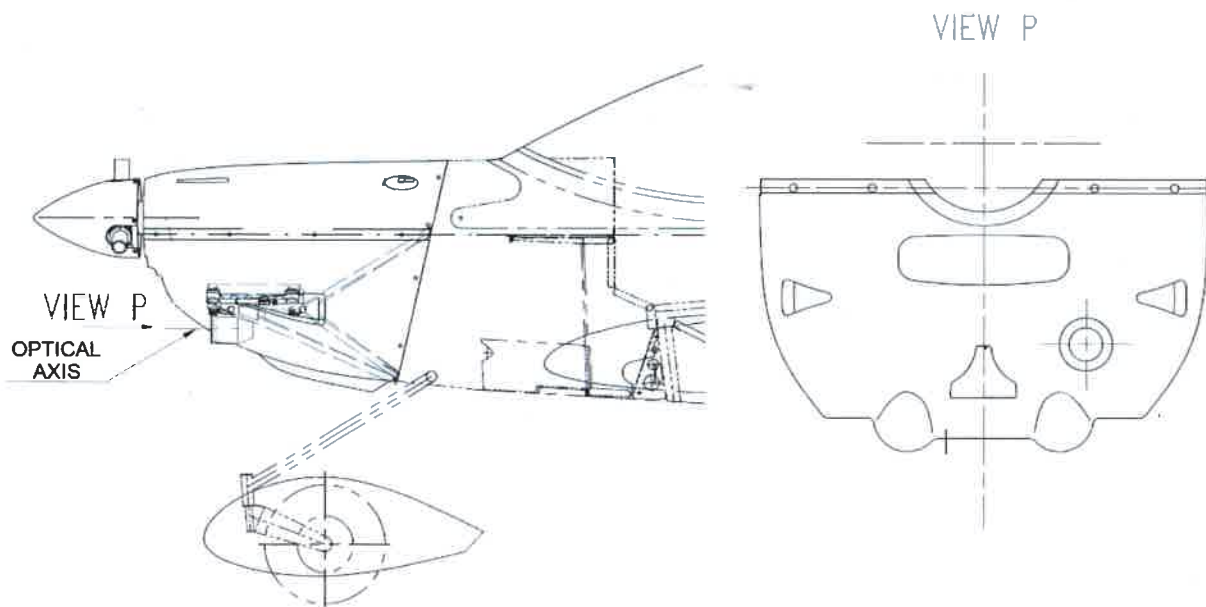

Figure 4 – Adjustment of the New landing light axis



CRUISER
AIRCRAFT

No.: SB-CR-042

Date: 2018-05-14

Page: 6 of 14

SERVICE BULLETIN

Czech Aircraft Group s.r.o.

Na Záhonech 212,

686 04 Kunovice

Czech Republic

info@cruiseraircraft.cz

Rev.: 3

Date: 2020-09-14

To replace the original TrailTech 4213-SX by the new Trail tech D112-SX landing light carry out the following steps:

- 1.1 Move the aircraft to a suitable place to perform the work.
- 1.2 Remove the engine upper cowling (see the CR-MM-1-0-00, the latest revision).
- 1.3 Disconnect the carburettor air inlet hose from the left NACA inlet of the lower cowling (see the CR-MM-1-0-00, the latest revision).
- 1.4 Disconnect the air inlet hose bringing the air into the heat exchanger (if installed) from the right NACA inlet of the lower engine cowling (see the CR-MM-1-0-00, the latest revision).
- 1.5 Remove the engine lower cowling, see the CR-MM-1-0-00, the latest revision.
- 1.6 Disconnect the battery terminals, see the CR-MM-1-0-00, the latest revision.
- 1.7 Disconnect the Original landing light from the aircraft wiring system - cable with the connector (6, 9) from the wiring (7, 8, 10), see Figure 1 above.
- 1.8 Remove the Original landing light (1) with bracket (2) from the engine mount.
- 1.9 Screw back the castle nut (12) and secure with the new cotter pin (13). To eliminate the slackness use the washer (33).
- 1.10 Install the New landing light (23) with the new holder (21, 29, 30) supplied by the Czech Aircraft Group using connecting parts (20, 31, 32, 22, 25, 26, 27, 28, 35), see Figure 2.

Attention:

The New landing light (23) has two brightness modes:

2500 Lumens – yellow wire connected and 1250 Lumens - red wire connected.

Remember that the New landing light can only be operated at 1250 Lumens, otherwise there might be a risk of overloading the 12V DC supply.

Therefore, ensure that the +12VDC voltage is connected to the red and - (0 V) to the black wire.

- 1.11 If the gap between the light mounting (23) and the threaded eye (27) on the screw (22) is 0,5 mm or more, insert the washer (34) between the light mounting and the threaded eye. Tighten the screw (22) firmly.
- 1.12 Interconnect the airplane connector (8) with the landing light connector (24), see Figure 1 and Figure 3 above.
- 1.13 Install the engine lower cowling and check the landing light position – it must be adjusted so that the optical axis of the landing light passes through the middle of the engine lower cowling opening, see Figure 3 and Figure 4. Use the parts (21, 29, 30) for adjustment.

Note: To reach the adjustment parts (21, 29, 30), the engine lower cowling has to be removed first.

To check the adjustment, the engine lower cowling has to be installed first.

- 1.14 Once a correct landing light position is set, remove the engine lower cowling and secure the adjustment by tightening the nut (28) and connecting parts (20, 31, 32).
- 1.15 Find the circuit / switch circuit breaker of the landing light (LDG L) on the instrument panel (see the CR-MM-1-0-00, latest revision) and check the rating. The range of 3A is correct current rating for the New landing light circuit / switch circuit breaker rating.



CRUISER
AIRCRAFT

No.: SB-CR-042

Date: 2018-05-14

Page: 7 of 14

SERVICE BULLETIN

Czech Aircraft Group s.r.o.

Na Záhonech 212,

686 04 Kunovice

Czech Republic

info@cruiseraircraft.cz

Rev.: 3

Date: 2020-09-14

Note: In the **PS-28 Cruiser** airplanes with analogue or **D100/D120** avionics equipment installed, the original MS3320-x circuit breaker has to be replaced by the **MS3320-3 (3A)** circuit breaker (marked "LDG L"). **The circuit breaker is placed on the right instrument panel.**

In the **PS-28 Cruiser** airplanes with **Dynon SkyView D1000** installed and in the **Sport Cruiser / Piper Sport** airplanes, the original W31X2M1G-x switch circuit breaker has to be replaced by the **W31X2M1G-3 (3A)** switch circuit breaker (marked "LDG L"). **The switch circuit breaker is placed on the left instrument panel.**

1.16 If the current rating of the circuit / switch circuit breaker specified in the point 1.15 is correct (3A), continue with the point 1.17. Otherwise continue with the following section 2 or 3, as applicable:

2 - "Replacement of the MS3320-x by the MS3320-3 circuit breaker" or

3 - "Replacement of the W31X2M1G-x by the W31X2M1G-3 (3A) switch circuit breaker", as applicable.



SERVICE BULLETIN

2 Replacement of the MS3320-x by the MS3320-3 circuit breaker.

(valid for PS-28 Cruiser airplanes with analogue or D100 / D120 avionics equipment installed)

NOTE: Numbering of parts used in this Section 2 belongs to Figure 5, 6 and 7 below.

General:

The MS3320 LDG L circuit breaker is installed on the right instrument panel, see Figure 5, The circuit breaker is marked "LDG L". Replacement of the circuit breaker has no effect on mass and CG of the airplane.

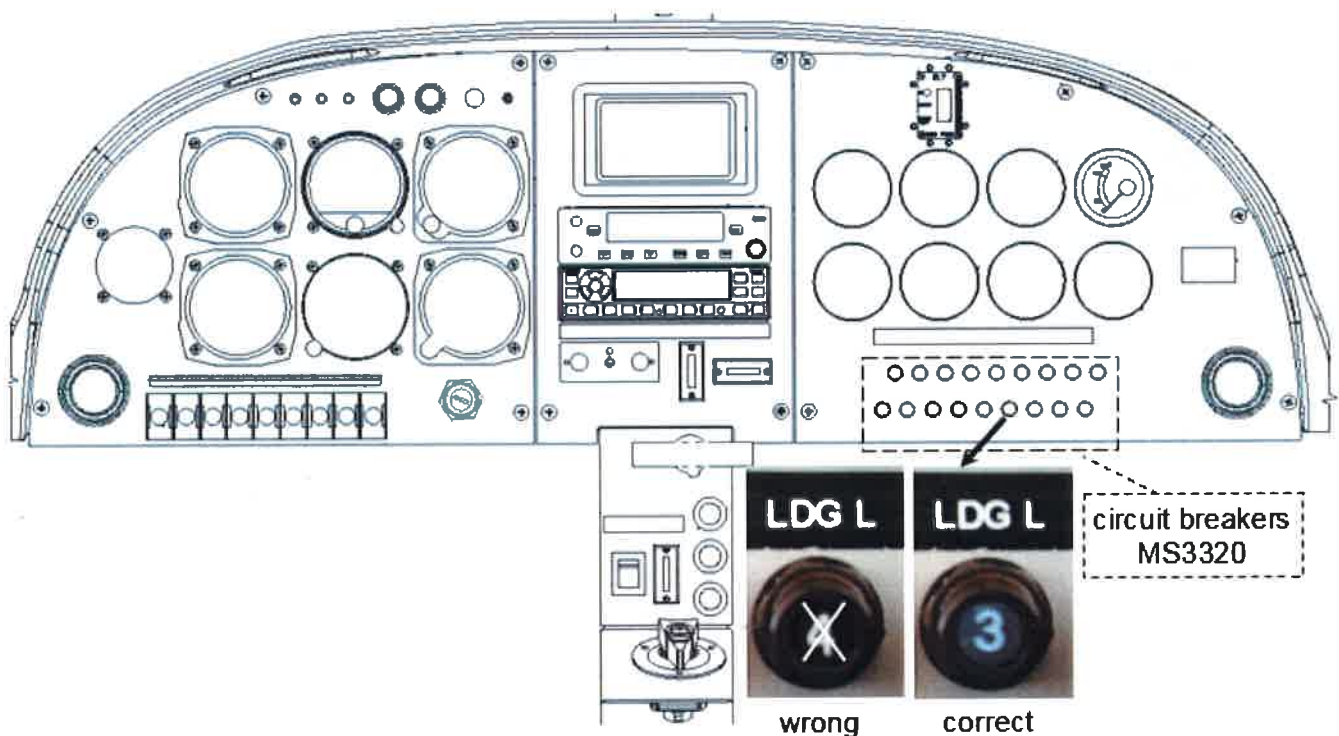

Figure 5 - The LDG L MS3320-x circuit breaker. Placed on the right instrument panel

Note: The instrument panel on Figure 5 is illustrative only, and may differ depending on the aircraft equipment.

To replace the LDG L circuit breaker, carry out the following steps:

- 2.1 Determine the LDG L circuit breaker (text "LDG L") on the right instrument panel, see Figure 5.
- 2.2 Secure that the MASTER BATT switch is turned off and disconnect the battery terminals, see the CR-MM-1-0-00, point 11.3.2, latest revision.
- 2.3 Remove the screws (2) with the washers (3) from the main supply bus (4) of all the circuit breakers, see Figure 6.



SERVICE BULLETIN

- 2.4 Remove the main supply bus (4) from the all circuit breakers (1) on the right instrument panel, see Figure 6.

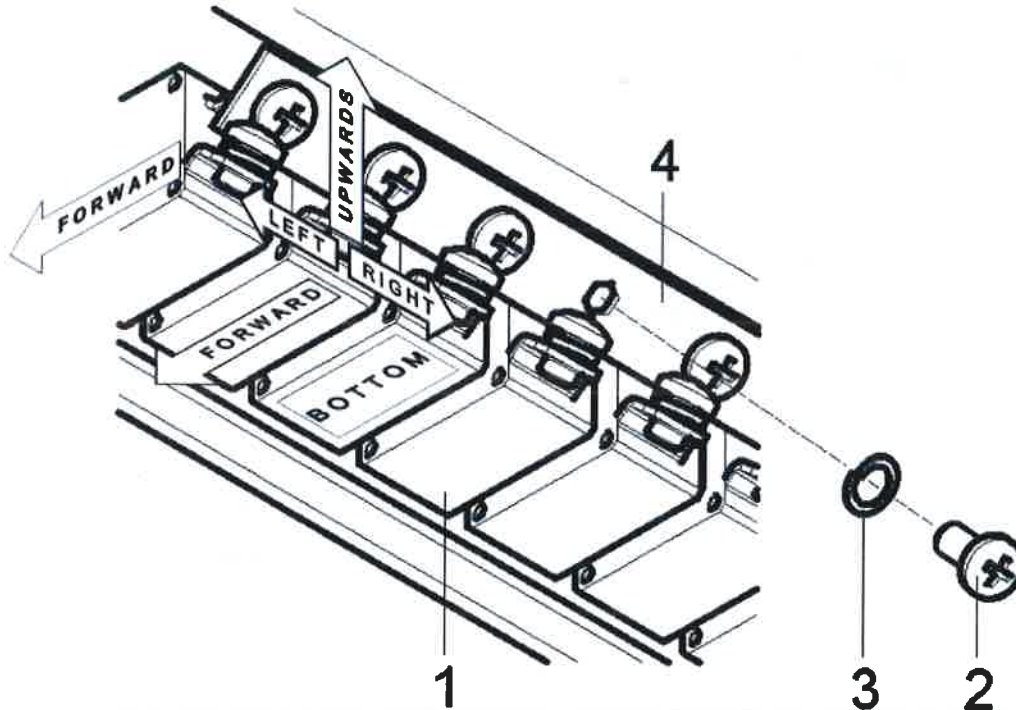

- | | |
|----------------------------|-------------------|
| 1 Circuit breaker MS3320-x | 3 Lock washer |
| 2 Screw | 4 Main supply bus |

Figure 6 - Connection of the MS3320-x circuit-breakers to the main supply bus

- 2.5 Release the screw (4) with the washer (5) and disconnect the cable (6) from the LDG L circuit breaker, see Figure 7.
- 2.6 Unscrew the nut (2), the washer (3) and remove the original LDG L circuit breaker (1), see Figure 7. To unscrew the nut (2) use the ½ inch wrench.
- Note:** The MS3320-3 circuit breaker hardware - screw (4), nut (2), washers (3; 5), see Figure 7, are included in the replacement package that shall be provided by the aircraft manufacturer.
- 2.7 Use the new LDG L circuit breaker from the replacement package (MS3320-3, current range of 3A), see Figure 5. Insert the circuit breaker in the right instrument panel and fix using the nut (2) with the washer (3), see Figure 7.
- 2.8 Connect the cable (6) using the screw (4) with the washer (5), see Figure 7.
- 2.9 Fix the main supply bus (4) back to the all circuit breakers using the screws (2) with the washers (3), see Figure 6.



SERVICE BULLETIN

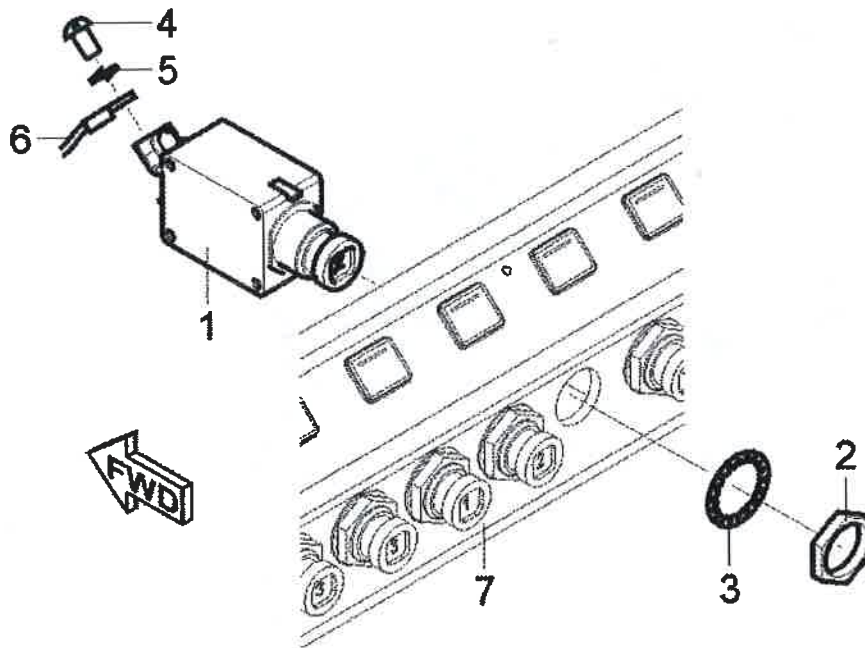

- | | |
|-------------------------|--------------------------|
| 1 LDG L Circuit-breaker | 5 Lock washer |
| 2 Nut | 6 Cable |
| 3 Lock washer | 7 Right instrument panel |
| 4 Screw | |

Figure 7 - MS3320-x circuit breaker removal / installation

- 2.10 Connect the battery terminals (see the CR-MM-1-0-00, point 11.3.3, latest revision), turn the MASTER BATT switch ON, switch the LDG L switch circuit breaker **on the LEFT instrument panel ON** and verify function of the new LDG L circuit breaker on the RIGHT instrument panel (switch it ON / OFF).
- 2.11 Replace the affected POH pages (dependent on the airplane version, will be delivered with the replacement package).
- 2.12 Continue with the point 1.18 below.

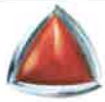

CRUISER
AIRCRAFT

No.: SB-CR-042

Date: 2018-05-14

Page: 11 of 14

SERVICE BULLETIN

Czech Aircraft Group s.r.o.
Na Záhonech 212,
686 04 Kunovice
Czech Republic
info@cruiseraircraft.cz

Rev.: 3

Date: 2020-09-14

3 Replacement of the W31X2M1G-x by the W31X2M1G-3 (3A) switch circuit breaker. (valid for PS-28 Cruiser airplanes with Dynon SkyView D1000 and Sport Cruiser / Piper Sport airplanes)

NOTE: Numbering of parts used in this Section 3 belongs to the Figure 8, 9 and 10.

General:

The W31X2M1G-x switch circuit breaker (marked "LDG L") is placed on the left instrument panel. Replacement of the switch circuit breaker has no effect on mass and CG of the airplane.

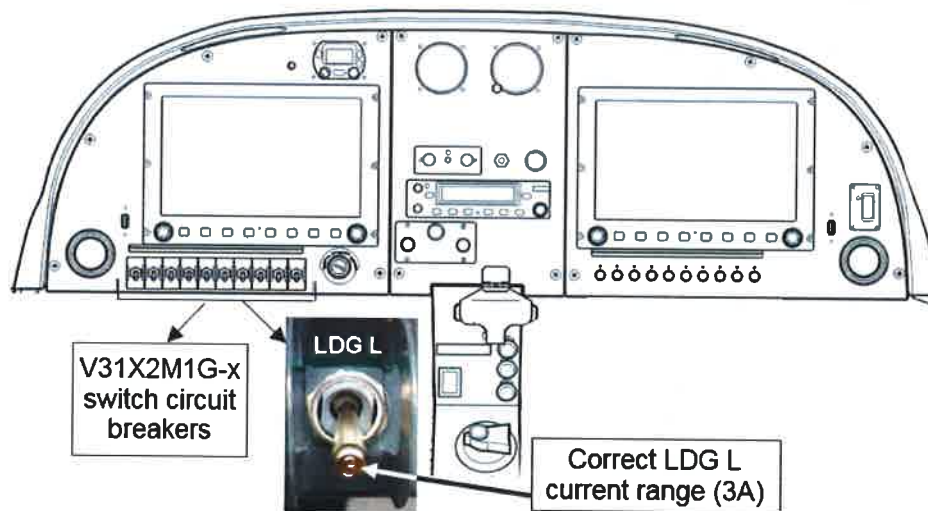

Figure 8 - The LDG L W31X2M1G-x switch circuit breaker. Placed on the left instrument panel

Note: The instrument panel on Figure 8 is illustrative only, and may differ depending on the aircraft equipment.

To replace the LDG L switch circuit breaker, carry out the following steps:

- 3.1 Determine the LDG L switch circuit breaker (text "LDG L") on the left instrument panel, see Figure 8.
- 3.2 Secure that the MASTER BATT switch is turned off and disconnect the battery terminals, see the CR-MM-1-0-00, point 11.3.2, latest revision.
- 3.3 Release the screws (2) with the washers (3) of all the switch circuit breakers and remove the main supply bus (4), see Figure 9.



SERVICE BULLETIN

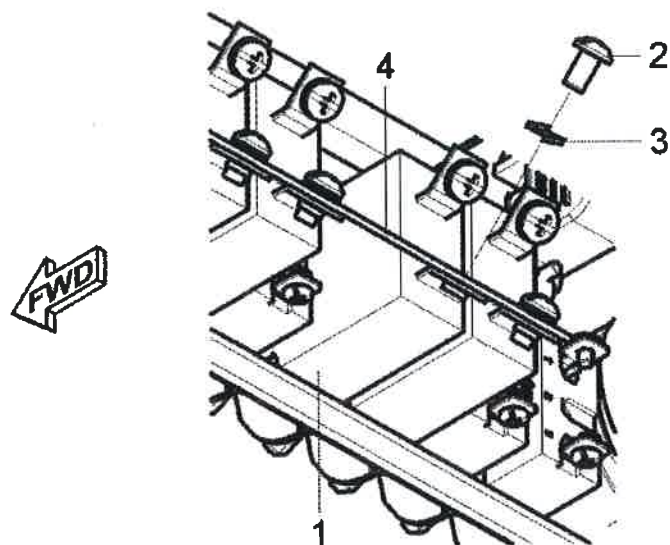

1. Switch circuit breaker
2. Screw
3. Lock washer
4. Main supply bus

Figure 9 - Connection the new LDG L W31X2M1G-3 switch circuit breaker to the main supply bus.

3.4 Remove the nut (2), the washers (3, 4) and cover (5) of the original LDG L switch circuit-breaker (1), see Figure 10.

3.5 Remove the screw (6) with the washer (7), and disconnect the original LDG L switch circuit-breaker cable (8), see Figure 10. Remove the original LDG L switch circuit breaker (1).

Note: The new W31X2M1G-3 switch circuit breaker hardware; screws (6), nut (2), washers (3; 4; 7), see Figure 10, are included in the package.

3.6 Use the new W31X2M1G-3 LDG L switch circuit breaker (current range of 3A) from the replacement package and insert it in the left instrument panel instead of the original switch circuit bracket. Apply the cover (5) and fix the switch circuit breaker using the nut (2) with the washers (3, 4), see Figure 10.

3.7 Use the screw (6) with the washer (7) and connect and fix the cable (8) to the new switch circuit breaker (1), see Figure 10.

3.8 Fix the main supply bus (4) back to the all switch circuit breakers using the screws (2) with the washers (3), see Figure 9.

3.9 Check attachment of the all switch circuit breakers (1), see the Figure 9 and the Figure 10.



SERVICE BULLETIN

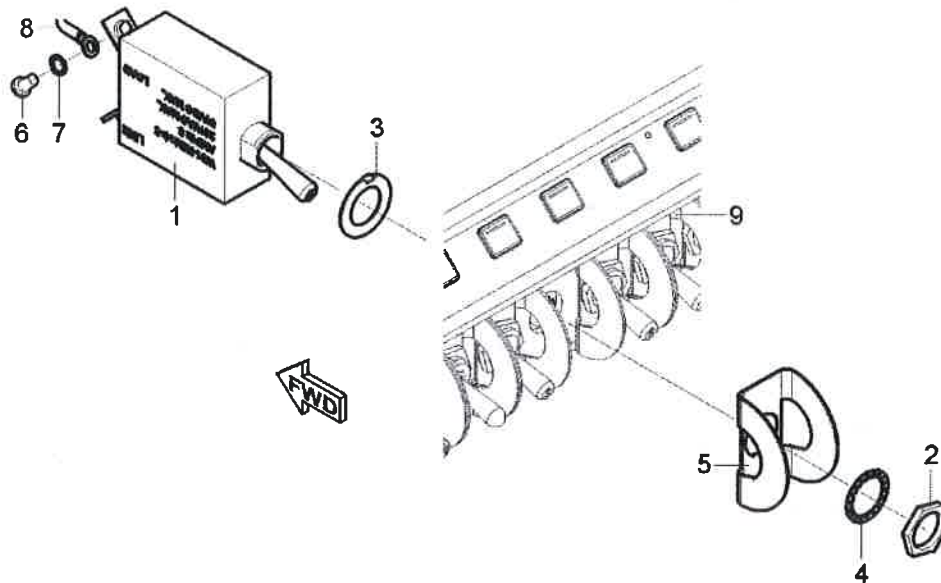

1 Circuit-breaker

2 Nut

3 Key washer

4 Lock washer

5 Cover

6 Screw

7 Lock washer

8 Cable

For information:

9 Left instrument panel

Figure 10 - W31X2M1G-x switch circuit breaker removal / installation

- 3.10 Connect the battery, switch the electrical network on and perform functional test of the new circuit-breaker (switch it ON / OFF).
- 3.11 Replace the affected POH pages (dependent on the airplane version, will be delivered with the replacement package).
- 3.12 Continue with the point 1.18.

-
- 1.17 Connect the battery terminals.
 - 1.18 Install the engine lower cowling (see the CR-MM-1-0-00, the latest revision)
 - 1.19 Connect the carburettor air inlet hose to the left NACA inlet of the lower cowling (see the CR-MM-1-0-00, the latest revision).
 - 1.20 Connect the air inlet hose bringing the air into the heat exchanger (if installed) to the right NACA inlet of the lower engine cowling (see the CR-MM-1-0-00, the latest revision).
 - 1.21 Mount the engine upper cowling (see the CR-MM-1-0-00, the latest revision).
 - 1.22 Perform functional test of the New landing light (switch the light on and verify that all three LED lights are alright).
 - 1.23 Complete the aircraft records (log book) to reflect compliance with this bulletin.



**CRUISER
AIRCRAFT**

No.: SB-CR-042

Date: 2018-05-14

Page: 14 of 14

SERVICE BULLETIN

Czech Aircraft Group s.r.o.

Na Záhonech 212,

686 04 Kunovice

Czech Republic

info@cruiseraircraft.cz

Rev.: 3

Date: 2020-09-14

APPROVAL:

This SB was approved by:

Title	Head of the Design Organisation	Airworthiness Manager
Name	Jiří Sklenář	Jiří Sklenář
Hand written signature	