



CRUISER
AIRCRAFT

No.: SB-CR-103

DATE: 2023-08-02

PAGE: 1/8

SERVICE BULLETIN

Czech Aircraft Group s.r.o.
Na Záhonech 212
686 04 Kunovice
Czech Republic
info@cruiseraircraft.cz

REV.: -

DATE: -

MODEL AFFECTED:	PS-28 Cruiser / PS-28N Cruiser SportCruiser / PiperSport operating under EASA rules
SUBJECT:	Accomplishment of ROTAX Bulletin SB-912-077UL / SB-912-077. Exchange of stator assy. for ROTAX 912 Aircraft Engines.
AIRCRAFT AFFECTED:	All aircrafts with 912 S and 912 ULS engines.
COMPLIANCE:	-On undelivered engines prior to delivery -Before the initial installation in an aircraft and/or spare part -Carry out this exchange of the stator on the engines listed in APPLICABILITY, according to the instructions in section 3 at the next ROTAX scheduled maintenance event, but at the latest after 1 year (from the date of the initial issue of this SB) These maintenance instructions shall be considered at any maintenance events, retrofitting, repair and overhaul.

DESCRIPTION:

This Service Bulletin contain instructions how to exchange of stator assy. for ROTAX 912 Aircraft Engines.

AUTHORISATION TO PERFORM:

- ROTAX - Airworthiness representatives
- ROTAX - Authorized Distributors or their independent Service Centers
- Persons approved by the respective Aviation Authorities
- Persons with approved qualifications for the corresponding engine types. Only authorized persons (iRMT, Level Heavy Maintenance) are entitled to carry out this work
- Persons with type-specific training

APPLICABILITY:

Engines 912 S and 912 ULS have been originally delivered from factory with the affected stator part no. 891095. See Appendix 02.

REASON:

Due to a deviation in the manufacturing process, some stator assemblies may fail on one ignition circuit.

MANPOWER:

3,5 hours

PUBLICATIONS AFFECTED:

N/A

WEIGHT AND BALANCE:

N/A

ELECTRICAL LOAD DATA:

N/A

REFERENCES:

SB-912-077UL / SB-914-058UL

SB-912-077 / SB-914-058

POH - Pilot's Operating Handbook (use appropriate POH for specific aircraft S/N)

CR-MM-1-0-00 PS-28 Cruiser Maintenance Manual

Other Rotax publications:

- in general Illustrated Parts Catalog (IPC) and in particular: Ch. 24-20-00 and Ch. 74-20-00

- in general Installation Manual (IM) and in particular: Ch. 24-00-00

- in general Maintenance Manual Line (MML) and in particular: Ch. 12-20-00

- in general Maintenance Manual Heavy (MMH) and in particular: Ch. 24-20-00 and Ch. 74-00-00

MATERIAL AND COSTS:

A labor credit will be provided for work performed by a technician with current applicable iRMT rating.

SPECIAL TOOLS:

PART No.	QUANTITY	DESCRIPTION	APPLICATION
897651	As required	Loctite 243	Flywheel hub
897330	As required	Lithium-base grease	Stator grounds
240880	1	Locking pin	Crankshaft
877417	1	Protection mushroom	Crankshaft
105 mm (4.1 in)*	1	Puller assy.	Flywheel hub
38 mm (1.4 in)*	1	Puller assy.	Flywheel hub

*Depending on the installation situation 2 variations of the puller assy. of different length are available. See Fig. 1.

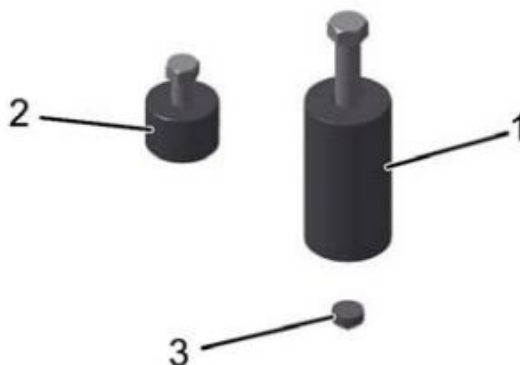

- 1 part no. 877375 Puller assy.
- 2 part no. 877377 Puller assy.
- 3 part no. 877417 Protection mushroom

Fig. 1: Pullers

MATERIAL:

PART No.	QUANTITY	DESCRIPTION	APPLICATION
891095	1 pc	Stator assy.	Engine type 912 and 914 Series
945830	6 pcs	Lock washer A5	Stator, cable clamps
945769	1 pc	Lock washer A16	Flywheel hub
950141	1 pc	Gasket ring A 8x13	Locking pin bolt
866710	3 pcs	Tie wrap 142x2.5 mm	Stator wiring
851250	2 pcs	Cable clamp 15/M5	Stator wiring
240187	5 pcs	Allen screw M5x25	Cable clamp
840514	1 pc	Allen screw M5x16	Cable clamp
940882	1 pc	Allen screw M5x30	Stator, cable clamps

ACCOMPLISHMENT INSTRUCTIONS:

NOTE: During the implementation of this SB follow AC43-13 and CR-MM-1-0-00.

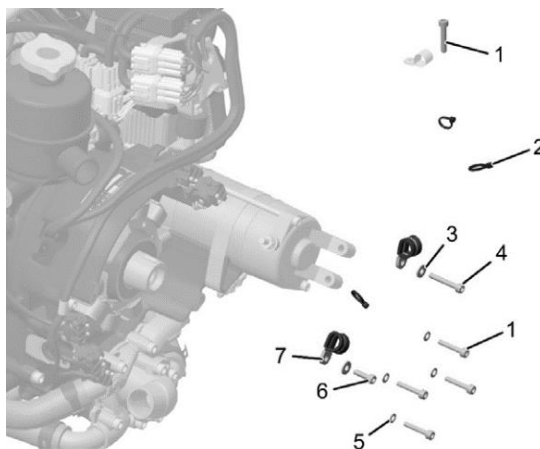

- 1 part no. 240187 Allen screw M5x25
- 2 part no. 866710 Tie wrap 142x2.5 mm
- 3 part no. 945830 Lock washer A5
- 4 part no. 940882 Allen screw M5x30
- 5 part no. 945830 Lock washer A5
- 6 part no. 840514 Allen screw M5x16
- 7 part no. 851250 Cable clamp 15/M5

Fig. 2: Screws

- 1) Check the criteria given on page 1, if the aircraft engine is affected by this SB.
- 2) Check the engine logbook and maintenance documentation, if this SB has already been accomplished.
- 3) Move the aircraft to a place suitable to perform the work.
- 4) Check the serial number. See Fig. 3.

SERVICE BULLETIN

NOTE: The stator's serial number can be viewed by rotating the flywheel hub until a lightening hole is aligned at approximately 4 o'clock position.



1 Stator serial number

Fig. 3: Stator

NOTE: Turn the propeller slowly in the direction of normal rotation until the stator serial number is visible through one of the larger flywheel hub lightening holes.

- 5) Flywheel hub and stator-removal, disassembly/assembly and installation:
- Restore aircraft to original operating configuration.
 - Connect negative terminal of aircraft battery.

NOTE: For removal, disassembly/assembly and installation see current Maintenance Manual Heavy (MMH) Chapter 24-20-00 for the respective engine type.

- 6) Perform engine run test (see CR-MM-1-0-00, Chapter 10).

NOTE: See Chapter 12-20-00 of the latest Maintenance Manual Line (MML) for the respective engine type.

NOTE: If engine is still within its original packaging the (blue) plastic bag must be carefully re-sealed after performing this inspection. The plastic bag contains a Volatile Corrosion Inhibitor (VCI) essential to maintain appropriate storage conditions.

- 7) Update aircraft records to reflect compliance with this Service Bulletin.
- 8) All used parts are unserviceable and must be returned FCA (Free Carrier) to ROTAX authorized distributors or their independent Service Centers.

APPENDIX 01:

The following drawings should convey additional information:

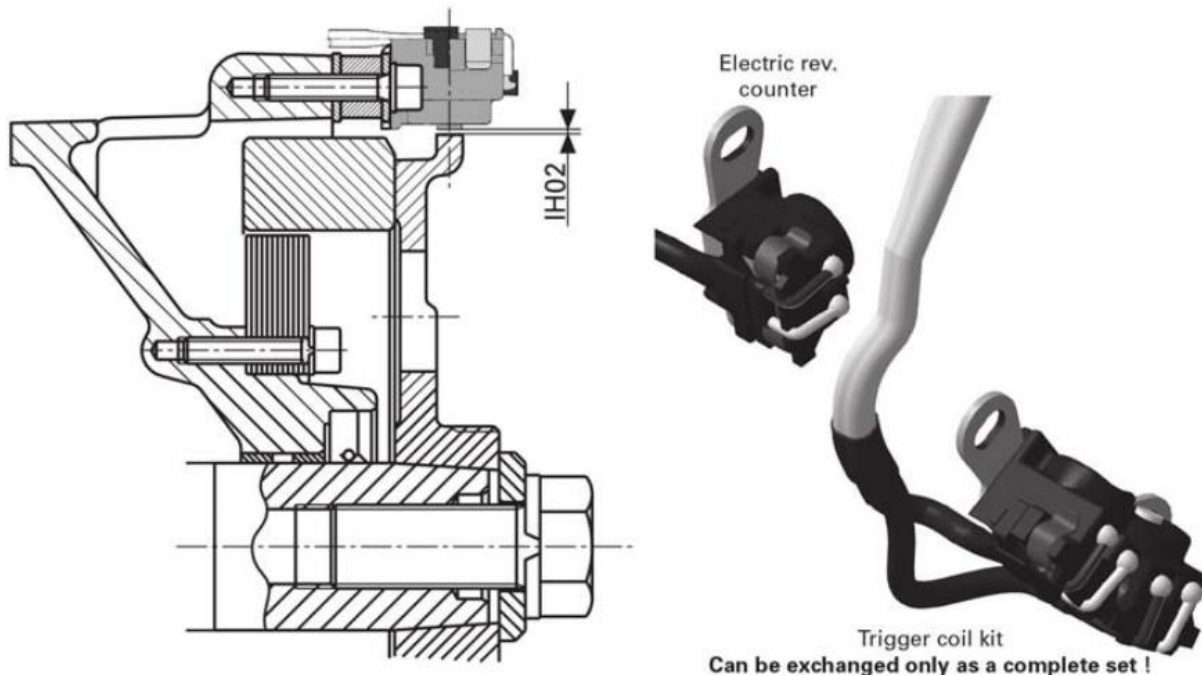

Fig. 4: Gap trigger coil.

DESCRIPTION	CODE	READING NEW		WEAR LIMIT		READINGS				
		min.	max.	100%	50%	A 1/2	A 3/4	B 1/2	B 3/4	
Trigger coil gap "old type"	IH02	0.4 mm (0.016 in)	0.5 mm (0.02 in)			actual				
Trigger coil gap (with clamps)	IH02	0.3 mm (0.012 in)	0.4 mm (0.016 in)			actual				
						renewed				
						renewed				

NOTE:

The illustrations in this document show the typical construction. They may not represent full detail or the exact shape of the parts which have the same or similar function.

Exploded views are not technical drawings and are for reference only. For specific detail, refer to the current documents of the respective engine type.



CRUISER
AIRCRAFT

No.: SB-CR-103

DATE: 2023-08-02

PAGE: 6/8

SERVICE BULLETIN

Czech Aircraft Group s.r.o.

Na Záhonech 212

686 04 Kunovice

Czech Republic

info@cruiseraircraft.cz

REV.: -

DATE: -

APPENDIX 02:

ENGINE S/N	ENGINE TYPE	STATOR S/N	STATOR PART No.
4411678	912 A2-01	221743	891095
4411679	912 A2-01	221740	891095
4411680	912 A2-01	221741	891095
4411684	912 A2-01	221694	891095
4413215	912 F3-01	221779	891095
4413216	912 F3-01	221778	891095
4422737	914 F3-01	221762	891095
6776243	912 UL2-01	221706	891095
9140379	912 S2-01	221682	891095
9140380	912 S2-01	221712	891095
9140382	912 S2-01	221696	891095
9140383	912 S2-01	221715	891095
9140390	912 S3-01	221698	891095
9140391	912 S3-01	221723	891095
9140395	912 S2-01	221705	891095
9140396	912 S2-01	221704	891095
9140400	912 S3-01	221728	891095
9140401	912 S3-01	221775	891095
9140402	912 S3-01	221777	891095
9140403	912 S3-01	221776	891095
9140405	912 S2-01	221774	891095
9140406	912 S2-01	221773	891095
9140407	912 S2-01	221772	891095
9140408	912 S2-01	221691	891095
9140409	912 S2-01	221690	891095
9140410	912 S2-01	221688	891095
9140411	912 S2-01	221689	891095
9140412	912 S2-01	221731	891095
9140413	912 S3-01	221751	891095
9140414	912 S3-01	221729	891095
9140415	912 S3-01	221750	891095
9140416	912 S3-01	221730	891095
9140417	912 S3-01	221742	891095
9140420	912 S3-01	221749	891095
9140422	912 S3-01	221748	891095
9140423	912 S3-01	221711	891095
9140426	912 S2-01	221710	891095
9140432	912 S2-01	221718	891095
9140435	912 S2-01	221695	891095
9140437	912 S3-01	221719	891095



CRUISER
AIRCRAFT

No.: SB-CR-103

DATE: 2023-08-02

PAGE: 7/8

SERVICE BULLETIN

Czech Aircraft Group s.r.o.
Na Záhonech 212
686 04 Kunovice
Czech Republic
info@cruiseraircraft.cz

REV.: -

DATE: -

ENGINE S/N	ENGINE TYPE	STATOR S/N	STATOR PART No.
9140439	912 S3-01	221708	891095
9140440	912 S2-01	221717	891095
9140441	912 S2-01	221693	891095
9140442	912 S2-01	221692	891095
9140491	912 S2-01	221735	891095
9144963	912 ULS2-01	221727	891095
9144967	912 ULS2-01	221724	891095
9144975	912 ULS2-01	221678	891095
9144976	912 ULS2-01	221679	891095
9144985	912 ULS2-01	221795	891095
9144989	912 ULS2-01	221794	891095
9144991	912 ULS2-01	221792	891095
9144992	912 ULS2-01	221680	891095
9144993	912 ULS2-01	221793	891095
9145001	912 ULS2-01	221753	891095
9145002	912 ULS2-01	221752	891095
9145006	912 ULS2-01	221755	891095
9145007	912 ULS2-01	221754	891095
9145012	912 ULS2-01	221702	891095
9145014	912 ULS2-01	221703	891095
9145015	912 ULS2-01	221701	891095
9145016	912 ULS2-01	221767	891095
9145017	912 ULS2-01	221765	891095
9145018	912 ULS2-01	221739	891095
9145019	912 ULS2-01	221737	891095
9145020	912 ULS2-01	221769	891095
9145021	912 ULS2-01	221771	891095
9145022	912 ULS2-01	221770	891095
9145023	912 ULS2-01	221738	891095
9145024	912 ULS2-01	221783	891095
9145025	912 ULS2-01	221766	891095
9145026	912 ULS2-01	221736	891095
9145027	912 ULS2-01	221764	891095
9145028	912 ULS2-01	221781	891095
9145029	912 ULS2-01	221787	891095
9145030	912 ULS2-01	221785	891095
9145031	912 ULS2-01	221784	891095
9145032	912 ULS2-01	221786	891095
9145036	912 ULS2-01	221780	891095
9145039	912 ULS2-01	221686	891095
9145040	912 ULS2-01	221782	891095
9145041	912 ULS2-01	221684	891095
9145042	912 ULS2-01	221746	891095



CRUISER
AIRCRAFT

No.: SB-CR-103

DATE: 2023-08-02

PAGE: 8/8

SERVICE BULLETIN

Czech Aircraft Group s.r.o.
Na Záhonech 212
686 04 Kunovice
Czech Republic
info@cruiseraircraft.cz

REV.: -

DATE: -

ENGINE S/N	ENGINE TYPE	STATOR S/N	STATOR PART No.
9145043	912 ULS2-01	221685	891095
9145047	912 ULS2-01	221745	891095
9145048	912 ULS2-01	221768	891095
9145050	912 ULS2-01	221687	891095
9145052	912 ULS2-01	221744	891095
9145055	912 ULS2-01	221747	891095
9145058	912 ULS2-01	221700	891095
9145134	912 ULS2-01	221756	891095
9145135	912 ULS2-01	221757	891095
9145147	912 ULS2-01	221759	891095
9145149	912 ULS2-01	221758	891095
9145204	912 ULS2-01	221763	891095
9145214	912 ULS2-01	221732	891095
9578117	914 UL2-01	221726	891095
9578118	914 UL2-01	221677	891095
9578119	914 UL2-01	221725	891095
9581157	912 UL2-01	221683	891095
9581159	912 UL2-01	221697	891095
9581160	912 UL2-01	221722	891095
9581161	912 UL2-01	221720	891095
9581162	912 UL2-01	221721	891095
9581163	912 UL2-01	221681	891095
9581164	912 UL2-01	221714	891095
9581166	912 UL2-01	221699	891095
9581167	912 UL2-01	221713	891095
9581171	912 UL2-01	221707	891095
9581184	912 UL2-01	221790	891095
9581189	912 UL2-01	221791	891095
9581202	912 UL2-01	221734	891095
9581206	912 UL2-01	221761	891095
9581207	912 UL2-01	221733	891095
9581208	912 UL2-01	221760	891095

APPROVAL:

This Service Bulletin has been approved by:

TITLE:	Head of Design Organisation	Airworthiness Manager
NAME:	David Bilík	Jan Pejchar
HAND WRITTEN SIGNATURE:		