

 CRUISER AIRCRAFT	<h1>SERVICE BULLETIN</h1>	Czech Aircraft Group s.r.o. Na Záhonech 212 686 04 Kunovice Czech Republic info@cruiseraircraft.com
		Rev.: 1
		Date: 2021-01-28
		No. SB-CR-033
Date: 2016-03-18		
Page: 1 of 10		

MODEL AFFECTED:	PS-28 Cruiser SportCruiser / PiperSport - under EASA PtF operation only
SUBJECT:	Change from Cylinder Head Temperature to Coolant Temperature measurement method for aircraft equipped with Rotax 912 ULS and 912 S2 series engine with a new cylinder head design.
AIRCRAFT AFFECTED:	PS-28 Cruiser up to S/N C0556 including SportCruiser – all S/N PiperSport – all S/N
COMPLIANCE:	As per EASA AD 2015-0240 (for Rotax engines)

BACKGROUND INFORMATION & APPLICABILITY CHECK:

With the change to a new cylinder heads design introduced by Rotax applicable for 912 ULS2 engines from S/N 6 781 410 including and 912 S2 engines from S/N 4 924 544 including, or on all engines with type designation followed by suffix-01, or on all engines which have been later equipped with the new cylinder heads design of P/N 413185 at cylinder head measuring position 2/3, no longer the Cylinder Head Temperature is measured, but the Coolant Temperature. This results in a different temperature limit, including the change of indication on the instrument panel, extension of the air cooler inlet hole and necessity to update POH and AMM.

Based on the description above a check of the engine configuration of affected aircraft must be performed.

If the new cylinder heads design at the measuring positions (cylinder 2/3) is not found, the authorized maintenance personnel will enter to the aircraft log book: "The SB-CR-033 applicability has been checked with the result not applicable".

If the new cylinder heads design is found, the measures introduced by this Service Bulletin must be followed. See further text.

DESCRIPTION:

For aircraft with the new cylinder heads design described above the following actions must be executed:

1. Extension of the air cooler inlet hole in the original engine bottom cowling.
2. Actions applied hardware or software
 - 2.1 Engine temperature indicator replacement for aircraft equipped with analog indicators.
 - 2.2 EMS reconfiguration for aircraft equipped with Dynon EMS-D120.
 - 2.3 EMS reconfiguration for aircraft equipped with MFD Dynon SkyView.

AUTHORISATION TO PERFORM:

EASA Part M or Part 145 Maintenance organization

REASON:

In the course of continuous development and standardization with ROTAX® 912 Series, new cylinder heads with modifications in its mould had been introduced.

With the change to a new cylinder heads design (P/N 413185 at cylinder head position 2/3) no longer the Cylinder Head Temperature is measured, but the Coolant Temperature.

The measuring position of the temperature sensor has changed. With this new installation position of the temperature sensor, a loss of coolant can be recognized easily. The change to the new cylinder heads does not affect the cooling capacity.

 CRUISER AIRCRAFT	<h1>SERVICE BULLETIN</h1>	Czech Aircraft Group s.r.o. Na Záhonech 212 686 04 Kunovice Czech Republic info@cruiseraircraft.com
No. SB-CR-033		Rev.: 1
Date: 2016-03-18		Date: 2021-01-28
Page: 2 of 10		

Due to these changes the Coolant Temperature (CT) instead of the Cylinder Head Temperature (CHT) in the aluminium is displayed. For that reason it is necessary to check/correct the Coolant Temperature limit (120°C) displayed on the instrument panel, check/correct its naming (CT instead of CHT). To improve the engine cooling characteristics, an extension of the air cooler inlet hole in the engine bottom cowling is to be applied.

In order to reflect all these changes mentioned above the relevant currently valid documents has to be revised (POH, AMM) and adapted so that the Coolant Temperature of 120 °C (measured at the new measuring point on the new cylinder head) will constitute the only valid operating limit.

MANPOWER:

1. **Manpower for extension of the air cooler inlet hole in the original engine cowling**
Max. 8 hours for extension of the air cooler inlet hole in the original engine bottom cowling.
2. **Manpower for reconfiguration of hardware/software equipment**
 - 2.1. For aircraft equipped with analog indicators
Max. 1 hour for installation of new analog engine CT indicator.
 - 2.2. For aircraft equipped with Dynon EMS-D120 :
Max. 6 hours for reconfiguration of the Dynon EMS-D120.
 - 2.3. For aircraft equipped with MFD Dynon SkyView:
Max. 6 hours for reconfiguration of the MFD Dynon SkyView.

SPECIAL TOOLS - extension of the air cooler inlet hole in the engine bottom cowling:

Rulers, pencil and other common equipment to measure and mark the new hole edge
Saw or manual grinding tool to cut out the new hole edge
Quality lamination system for fiberglass works, fiberglass
Sanding paper with relevant grain size
Quality filler for smoothing the repaired surface
Another common tools for aircraft servicing.

SPECIAL TOOLS – new CT indicator installation: (valid for airplane with analogue instruments)

New engine CT indicator
Screw and common tools for replacement of the indicator.

SPECIAL TOOLS - reconfiguration of Dynon EMS-D120: (valid for airplanes with this system)

Notebook or PC
Communication cable for interconnection between Notebook and the Dynon EMS-D120
Dynon Product Support Programme, last Issue

SPECIAL TOOLS – reconfiguration of MFD Dynon SkyView: (valid for airplanes with this system)

Notebook or PC
USB Flash Drive

WEIGHT AND BALANCE:

Insignificant effect.

ELECTRICAL LOAD DATA:

Not affected.

 CRUISER AIRCRAFT	<h1>SERVICE BULLETIN</h1>	Czech Aircraft Group s.r.o. Na Záhonech 212 686 04 Kunovice Czech Republic info@cruiseraircraft.com
No. SB-CR-033		Rev.: 1
Date: 2016-03-18		Date: 2021-01-28
Page: 3 of 10		

REFERENCES:

N/A

PUBLICATIONS AFFECTED:

PS-POH-1-1-11, latest revision
PS-POH-1-1-12, latest revision
PS-POH-1-1-13, latest revision
CR-MM-1-0-00, latest revision
SC-AMM-1-0-00, latest revision

MATERIAL:

New analogue CT indicator Road IH91. 2B35.22 (nomencl. 6302MI22) can be ordered from Czech Aircraft Group s.r.o.

COSTS:

To be covered by the aircraft owner/operator.

 CRUISER AIRCRAFT	<h1>SERVICE BULLETIN</h1>	Czech Aircraft Group s.r.o. Na Záhonech 212 686 04 Kunovice Czech Republic info@cruiseraircraft.com
No. SB-CR-033		Rev.: 1
Date: 2016-03-18		Date: 2021-01-28
Page: 4 of 10		

GENERAL INFORMATION:

- a) **The engine serial number** is located on the top of the crankcase, magneto side.
 Basic scheme of the Rotax 912 engine with location of engine serial number and cylinder heads positions, see Figure 1.

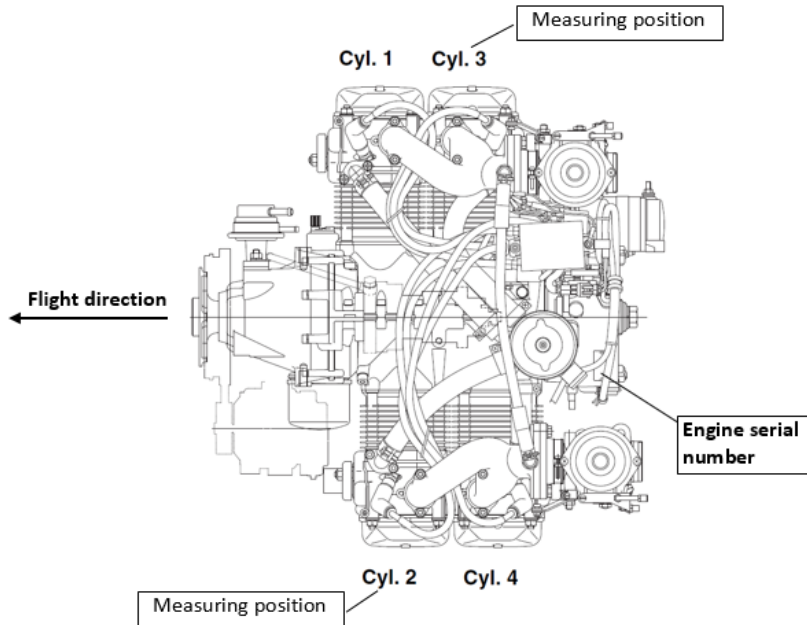

Figure 1 Location of the engine serial number and cylinder head positions

- b) **The temperature sensors** are located on cylinder 2 and 3. To recognize whether the engine is equipped with the new cylinder head design (P/N 413185 for 2/3 cylinder head) or not, read the Part number of the 2/3 cylinder heads, see Figure 2.

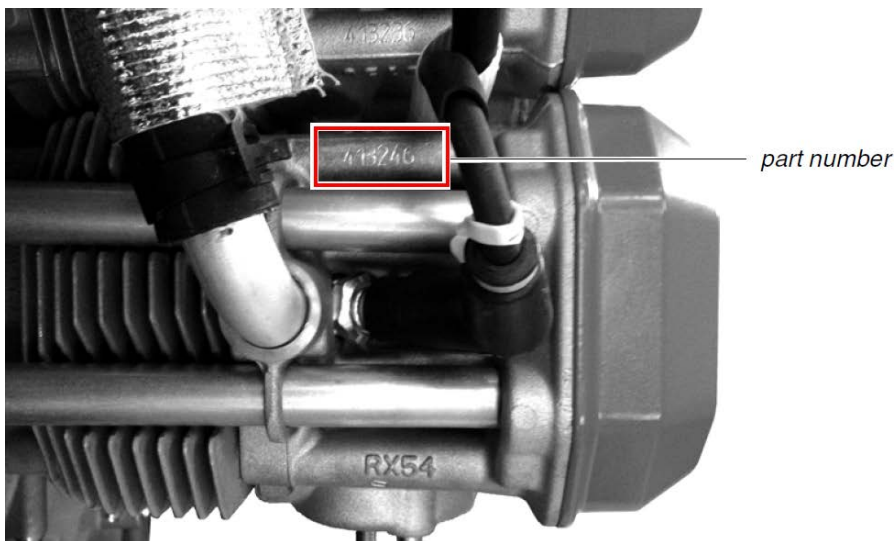

Figure 2 - Part number location of cylinder head



SERVICE BULLETIN

- c) To recognize the **difference between the old and new cylinder head design and the temperature sensor position**, see Figure 3.

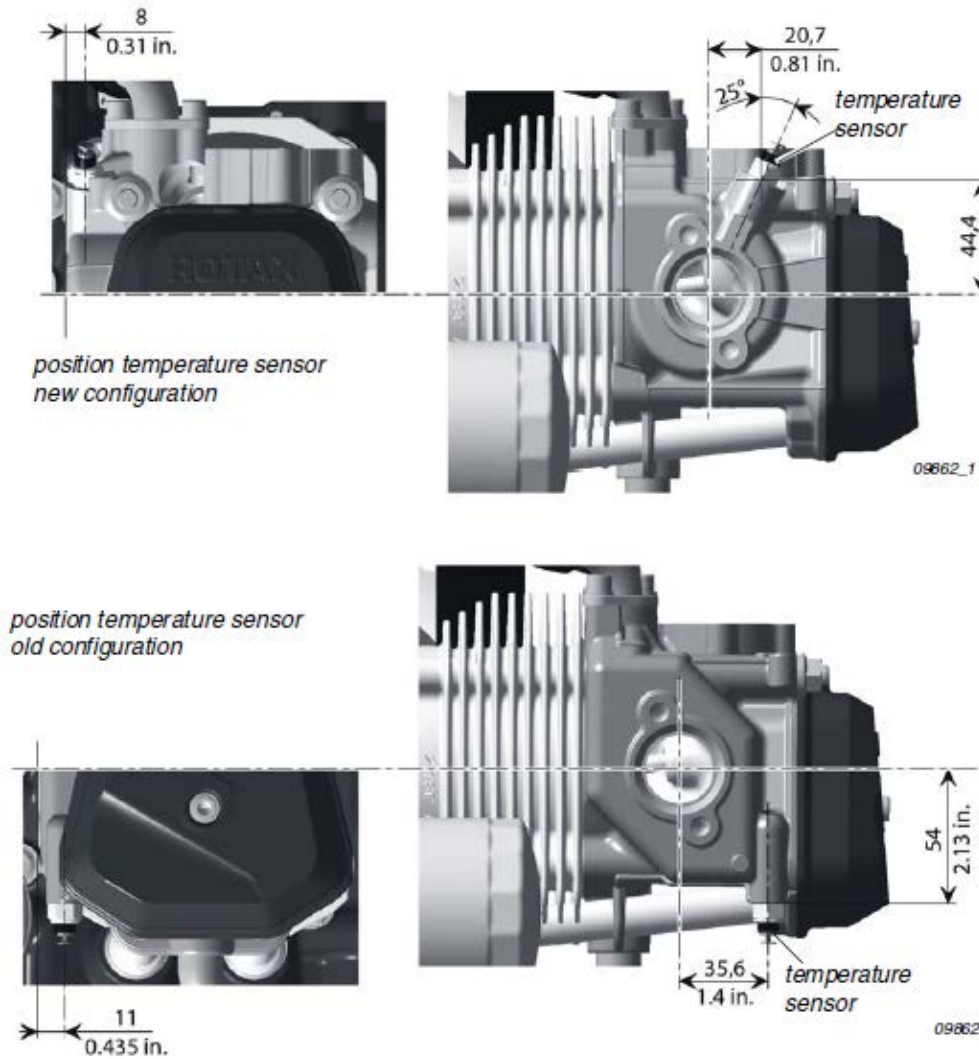

Figure 3 - Difference between old and new cylinder head design and temperature sensor position

- d) **Coolant temperature limit** (measured on cylinder head measuring point), see Table 1 .

Table 1 - Coolant temperature limit - Effective for engines with new cylinder head design (P/N 413185 for 2/3 cylinder head)

Coolant temperature limit for measuring point in the cylinder head (new configuration)	Maximum 120 °C (248°F)
--	------------------------

CAUTION

Waterless coolant are not allowed to be used for Rotax engines with new cylinder head design. Only conventional coolant based on ethylene glycol with 50% of water is permitted.

 CRUISER AIRCRAFT	<h1>SERVICE BULLETIN</h1>	Czech Aircraft Group s.r.o. Na Záhonech 212 686 04 Kunovice Czech Republic info@cruiseraircraft.com
No. SB-CR-033		Rev.: 1
Date: 2016-03-18		Date: 2021-01-28
Page: 6 of 10		

COOLANT USED BY MANUFACTURER:

Specification: ASTM D 3306, VW TL 744C-G11,
Mixture ratio coolant/water: 50/50 [%]
Max. coolant temperature: 120°C

For more details, see the SB-912-066, SB-912-066UL, SB-912-068 and SB-912-68UL Rotax bulletins, Rotax Installation Manual for engine type 912 series, Rotax Service Instruction SI-912-016.

ACCOMPLISHMENT INSTRUCTIONS:

To accomplish this bulletin carry out the following steps:

1. Move the aircraft to a suitable place to perform the work and remove the bottom and upper engine cowlings.
2. Check the engine serial number S/N, if the aircraft is affected by this SB, see Figure 1 above.
3. Check the part numbers of the cylinder heads at the measuring positions 2/3, see Figure 1 and Figure 2 above.
Send a written report to Czech Aircraft Group s.r.o. about the check result (Date, Aircraft S/N, New cylinder heads design was found/not found.)
4. In case the **new cylinder heads design is not found**, assemble the bottom and upper engine cowlings back. The authorized maintenance personnel will enter to the aircraft log book the following text: "The SB-CR-033 applicability has been checked with the result not applicable". **The SB-CR-033 performance is in this case hereby completed.**
5. In case the **new cylinder heads design** (P/N 413185 at the cylinder head position 2/3) **is found**, check if the suffix-01 on the type plate is present, see Figure 4 below. If the suffix-01 on the type plate is not present, ensure a permanent application of the suffix -01 (e.g. engraved, stamped or similar), see Figure 4.
Note: In case there is only one cylinder head of the new type (P/N 413185) at a single position 2 or 3 installed, ensure at authorized service organization that the cylinder head of the old type on the other position (2 or 3, as applicable) be replaced with a new type of the cylinder head having P/N 413185.
Any changes regarding to this Service Bulletin must be confirmed in the logbook
6. Check the indicating instruments in the cockpit whether the coolant temperature or cylinder head temperature is displayed.
7. Check the designation and operating limits of coolant temperature on the indicating instruments. The designation must be amended or corrected if necessary, see Table 1 above.
8. Check the maintenance documentation if a repair or maintenance was performed on one of the cylinder heads.
9. Go on with the point 10.

 CRUISER AIRCRAFT	<h1>SERVICE BULLETIN</h1>	Czech Aircraft Group s.r.o. Na Záhonech 212 686 04 Kunovice Czech Republic info@cruiseraircraft.com
		No. SB-CR-033
		Date: 2016-03-18
		Page: 7 of 10
		Rev.: 1
		Date: 2021-01-28

Figure 4 Check of the engine serial number S/N and the suffix -01 on the type plate. (see the whole SB-912-068 R1 from ROTAX for details)

SB-912-068 R1
 SB-914-049 R1

SERVICE BULLETIN

3.1.1) Correction of the type plate

NOTICE

The following suffix may only be added to indicate configuration changes / modifications / overhauls. The remaining content of the type plate must not be changed.

NOTICE

Prior to any changes to the type plate, the relevant national regulations must be observed and carried out in consultation with the aircraft manufacturer in any case.

Step	Procedure
1	Apply suffix - 01 permanently (e.g. engraved, stamped or similar) to the type plate. NOTE: Any changes regarding to this Service Bulletin must be confirmed in the engine logbook.

Fig. 1

Example:

OLD



OLD CHANGED



NEW



10235,
10236,10237

3.2) Test run

none.

3.3) Summary

These instructions (section 3) have to be followed in accordance with the deadlines specified in section 1.5.

The execution of the mandatory Service Bulletin must be confirmed in the logbook.



SERVICE BULLETIN

10. Extension of the air cooler inlet hole in the original engine bottom cowling.

- 10.1. Use the engine bottom cowling, measure out and mark new hole top edge acc. to the Figure 5 below. The new top edge is moved upwards.
- 10.2. Cut off the top rim accordingly to the marking and clean the hole.
- 10.3. Fit in place and adjust the cut off top rim and laminate it back in the extended cowling inlet hole.
- 10.4. Use an additional fiberglass and apply for laminating of side parts of the cowling hole.
- 10.5. Carry out sanding for good adhesion of the repair coats.
- 10.6. Apply a sufficient primer and top coat to restore the original colour design of the surface.

Figure 5 - extension of the air cooler inlet hole in the engine bottom cowling

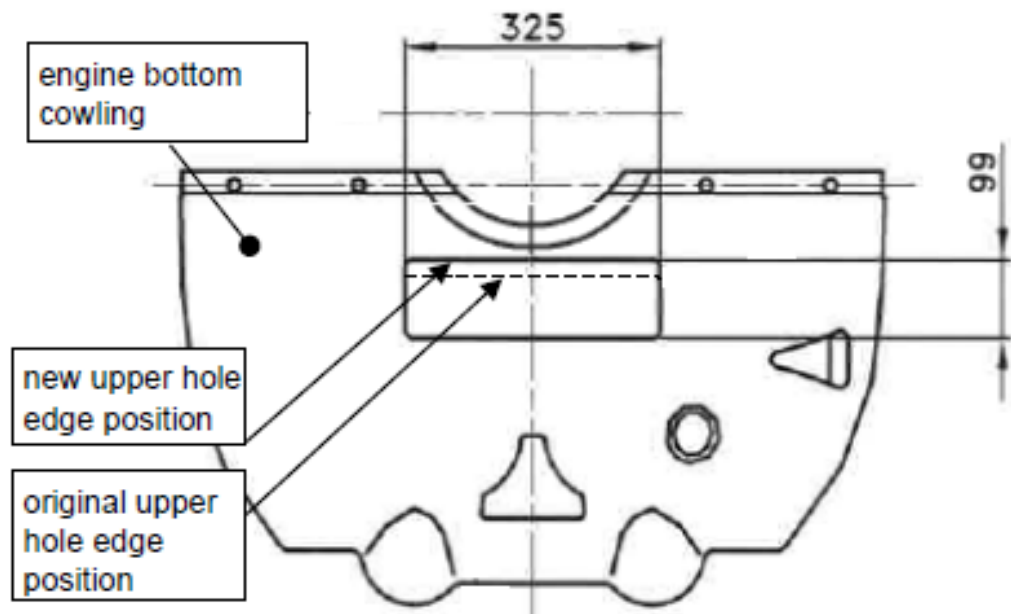

 CRUISER AIRCRAFT	<h1>SERVICE BULLETIN</h1>	Czech Aircraft Group s.r.o. Na Záhonech 212 686 04 Kunovice Czech Republic info@cruiseraircraft.com
No. SB-CR-033		Rev.: 1
Date: 2016-03-18		Date: 2021-01-28
Page: 9 of 10		

HARDWARE / SOFTWARE

A) Instructions valid for the aircraft equipped with analog indicators

1. Disconnect the positive battery terminal
2. Order new CT indicator from Czech Aircraft Group s.r.o. for replacement.
3. Replace the previous CHT indicator by the CT indicator – the maximum temperature limit is changed to 120°C.
4. Connect the indicator to the CT sensor. Comparing to the previous CHT indicator the electrical scheme/connection of the CT indicator is identical.
5. Connect the positive battery terminal
6. For PS-28 Cruiser aircraft - order POH pages for replacement from Czech Aircraft Group s.r.o., contact us at info@cruiseraircraft.com.
7. For SportCruiser and PiperSport - order POH pages for replacement from Czech Aircraft Group s.r.o., contact us at info@cruiseraircraft.com.
8. Order from Czech Aircraft Group s.r.o. the modified Supplement No.2.
9. Restore the aircraft to the airworthy condition.
10. Perform the engine run test and check the relevant systems.
11. Complete aircraft records to reflect compliance with this bulletin.

B) Instructions valid for the aircraft equipped with Dynon EMS-D120

Note: The Dynon EMS-D120 system does not give a possibility to change the temperature name shown on the screen from CHT to CT. Therefore the Coolant Temperature is indicated on the EMS-D120 screen further using the abbreviation „CHT“.

Operating range of indicated temperature must be reduced to 120 °C.

1. For procedure how to reconfigure the Dynon EMS-D120 the EASA Part M or Part 145 Maintenance organization will ask Czech Aircraft Group s.r.o.
2. For PS-28 Cruiser aircraft - order POH pages for replacement from Czech Aircraft Group s.r.o., contact us at info@cruiseraircraft.com.
3. For SportCruiser and PiperSport - order POH pages for replacement from Czech Aircraft Group s.r.o., contact us at info@cruiseraircraft.com.
4. Restore the aircraft to the airworthy condition.
5. Perform the engine run test and check the relevant systems.
6. Complete aircraft records to reflect compliance with this bulletin.

C) Instructions valid for the aircraft equipped with MFD Dynon SkyView

Note: The range of indicated temperature must be reduced to 120°C, the **CHT** name shown on the screen must be renamed to **CT**. (CHT L to **CT L** and CHT R to **CT R**)

1. For procedure how to reconfigure the MFD Dynon SkyView the EASA Part M or Part 145 Maintenance organization will ask Czech Aircraft Group s.r.o.
2. For PS-28 Cruiser aircraft - order POH pages for replacement from Czech Aircraft Group s.r.o., contact us at info@cruiseraircraft.com.
3. For SportCruiser and PiperSport - order POH pages for replacement from Czech Aircraft Group s.r.o., contact us at info@cruiseraircraft.com.

 CRUISER AIRCRAFT	<h1>SERVICE BULLETIN</h1>	Czech Aircraft Group s.r.o. Na Záhonech 212 686 04 Kunovice Czech Republic info@cruiseraircraft.com
No. SB-CR-033		Rev.: 1
Date: 2016-03-18		Date: 2021-01-28
Page: 10 of 10		

4. Restore the aircraft to the airworthy condition.
5. Perform the engine run test and check the relevant systems.
6. Complete aircraft records to reflect compliance with this bulletin.

APPROVAL:

This SB was approved by:

Title	Head of the Design Organisation	Airworthiness Manager
Name	Jiří Sklenář	Jiří Sklenář
Hand written signature	