



CRUISER
AIRCRAFT

No.: SB-CR-077

DATE: 2019-09-19

PAGE: 1/6

SERVICE BULLETIN

Czech Aircraft Group s.r.o.
Na Záhonech 212
686 04 Kunovice
Czech Republic
info@cruiseraircraft.cz

REV.: 2

DATE: 2024-06-06

MODEL AFFECTED:	PS-28 Cruiser / PS-28N Cruiser SportCruiser / PiperSport operating under EASA rules
SUBJECT:	Replacement of the original SG0030L/P main landing gear legs by the reinforced SG0160L/P variant
AIRCRAFT AFFECTED:	All PS-28 Cruiser and PS-28N Cruiser aircraft All SportCruiser / PiperSport operating under EASA rules
COMPLIANCE:	Apply this Service Bulletin, when replacement of the original SG0030L/P main landing gear legs is required

DESCRIPTION:

This Service Bulletin includes instructions for replacement of the original SG0030L/P main landing gear legs by the reinforced SG0160L/P variant.

AUTHORISATION TO PERFORM:

Part M or Part 145 Maintenance organization

REASON:

Reinforced SG0160L/P main landing gear legs have been developed by the aircraft manufacturer with the objective to further increase operational reliability of the aircraft, mainly in highly demanding operational conditions.

MANPOWER:

8 hours

SPECIAL TOOLS:

Common tools for aircraft maintenance.

WEIGHT AND BALANCE:

Affected

ELECTRICAL LOAD DATA:

N/A

PUBLICATIONS AFFECTED:

PS-28 Cruiser Maintenance Manual, CR-MM-1-0-00, latest revision

MATERIAL AND COSTS:

All costs to be covered by the aircraft owner / operator.



CRUISER
AIRCRAFT

No.: SB-CR-077

DATE: 2019-09-19

PAGE: 2/6

SERVICE BULLETIN

Czech Aircraft Group s.r.o.
Na Záhonech 212
686 04 Kunovice
Czech Republic
info@cruiseraircraft.cz

REV.: 2

DATE: 2024-06-06

MATERIAL:

LEFT SIDE			
ITEM No.	NOMENCLATURE	DESCRIPTION	QUANTITY
001	SG0160L	Main landing gear leg (left)	1 pc
004	3121B659	Self-locking nut	4 pcs
005	3131A616 ³	Washer	15 pcs
008	3121B655	Self-locking nut	4 pcs
010	SG0159L	Spacer (left)	1 pc
011	3121B654	Self-locking nut	8 pcs
012	3331A011	Zip tie	4 pcs
013	4410V002 ¹	Emfimastic PU50	1 pc
014	N/A ^{1,2}	3M Marine Adhesive Sealant 5200	1 pc

¹ one of these, ² order in local store, ³ intentional surplus due to flattened tube

RIGHT SIDE			
ITEM No.	NOMENCLATURE	DESCRIPTION	QUANTITY
001	SG0160P	Main landing gear leg (right)	1 pc
004	3121B659	Self-locking nut	4 pcs
005	3131A616 ³	Washer	15 pcs
008	3121B655	Self-locking nut	4 pcs
010	SG0159P	Spacer (right)	1 pc
011	3121B654	Self-locking nut	8 pcs
012	3331A011	Zip tie	4 pcs
013	4410V002 ¹	Emfimastic PU50	1 pc
014	N/A ^{1,2}	3M Marine Adhesive Sealant 5200	1 pc

¹ one of these, ² order in local store, ³ intentional surplus due to flattened tube

SERVICE BULLETIN

ACCOMPLISHMENT INSTRUCTIONS:

NOTE: During the implementation of this SB follow AC43-13 and MM, Chapter 15.

NOTE: This Service Bulletin is valid for both sides (left side shown).

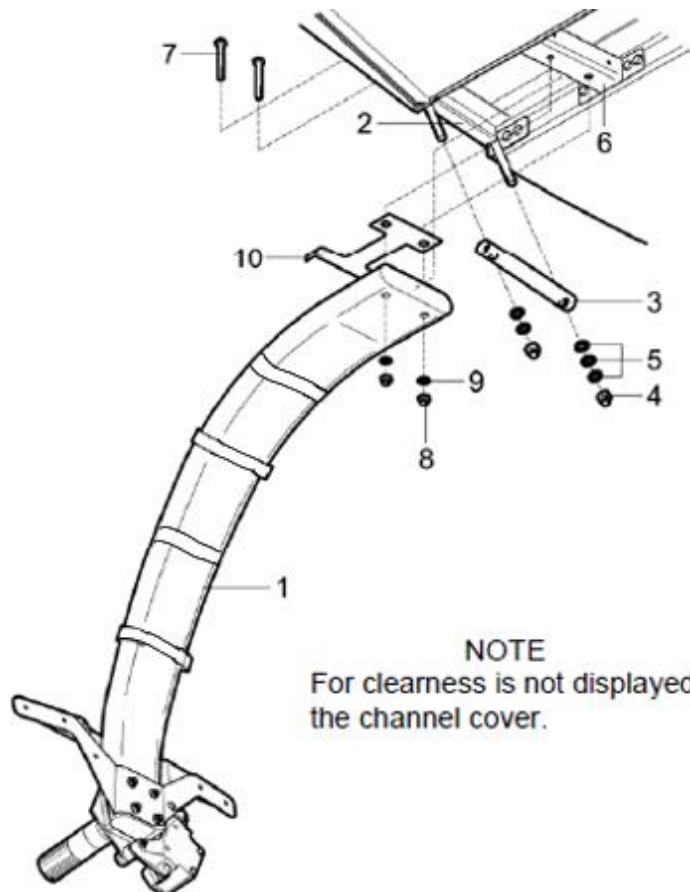

NOTE
For clearness is not displayed
the channel cover.

- | | | | |
|---|-----------------------|----|---------|
| 1 | Main landing gear leg | 6 | Chamber |
| 2 | Main gear attachment | 7 | Bolt |
| 3 | Tube | 8 | Locknut |
| 4 | Locknut | 9 | Washer |
| 5 | Washer | 10 | Spacer |

Fig. 1: Main landing gear leg

SERVICE BULLETIN

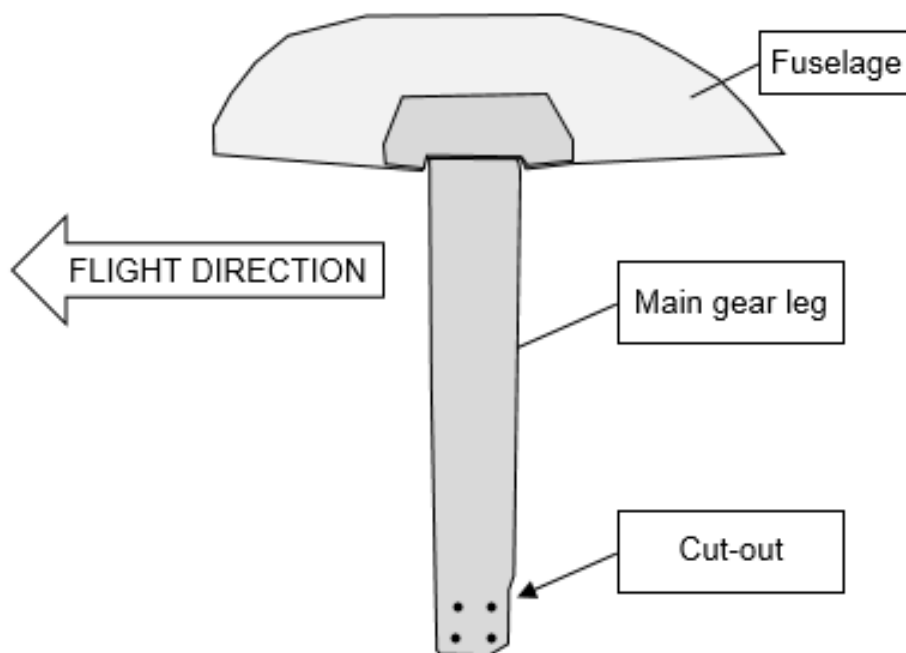

Fig. 2: Main gear leg installation (illustrative sketch)

REMOVAL OF THE ORIGINAL MAIN LANDING GEAR LEGS:

- 1) Move the aircraft to a place suitable to perform the work.
- 2) Follow the CR-MM-1-0-00, Chapter 8, latest revision and remove the main wheel fairings, the main landing gear wheel assembly and the original main landing gear legs.

INSTALLATION OF THE REINFORCED MAIN LANDING GEAR LEGS:

WARNING: IT IS NOT ALLOWED TO MIX THE ORIGINAL SG0030L/P AND THE REINFORCED SG0160L/P MAIN GEAR LEGS! BOTH THE LEFT AND THE RIGHT LEG MUST BE ALWAYS OF THE SAME TYPE.

- 3) Install the reinforced main landing gear legs, see the CR-MM-1-0-00, Chapter 8, latest revision.
- 4) Be careful of correct position according to the flight direction. The leg has to be installed so that the cut out on the leg bottom part must be on the rear side, see Fig. 2 above.
- 5) When the leg is inserted/pushed into the final position, drill two holes \varnothing 8 mm for bolts (7, Fig. 1) in the main landing gear attachment (2) and spacer (10).
- 6) Install the wheels assembly, see the CR-MM-1-0-00, Chapter 8, latest revision.

NOTE: Securing bolts (2) and (7): Use only as many washers (9, Fig. 1) so that when the locknut (4, 8) is tightened, the bolt thread should protrude throughout the locknut not less than 1,5 pitches beyond the top of the nut or plastic insert (see SAE ARP1515 or other aviation standards).

- 7) Check the brake function and carry out the "Conditioning procedures", see the CR-MM-1-0-00, Chapter 8, latest revision.

- 8) Assemble the main landing gear wheel fairing, as applicable, see the CR-MM-1-0-00, Chapter 8, latest revision.

INSTALLATION OF THE BRAKE HOSE HOLDERS:

- 9) Adjust the brake hose as shown (Fig. 3).
10) Secure the position of the zip ties with glue (013/014).

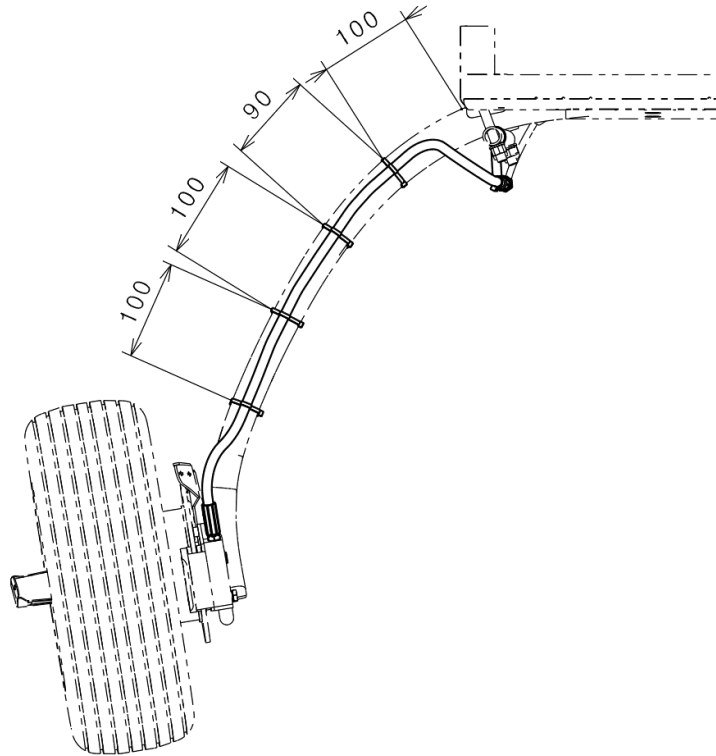

Fig. 3: Main gear leg zip tie position

- 11) Weigh the aircraft, calculate the current C.G. Position and write the results into POH. In case the current C.G. Position values exceed the front limit stipulated by the POH, proceed according to the instructions as per CR-MM-1-0-00, Chapter 3, latest revision.
- 12) Update aircraft records to reflect compliance with this Service Bulletin.



CRUISER AIRCRAFT

No.: SB-CR-077

DATE: 2019-09-19

PAGE: 6/6

SERVICE BULLETIN

Czech Aircraft Group s.r.o.
Na Záhonech 212
686 04 Kunovice
Czech Republic
info@cruiseraircraft.cz

REV.: 2

DATE: 2024-06-06

APPENDIX: PAINTING THE LEG (OPTIONAL)

NOTE: Mixed colours or painted legs can be ordered from the Cruiser Aircraft Group.

- A. For variant with white colour of the main gear leg and sleeves, the procedure for mixing colour is as follows:
- PT 101 (Cromax Imron fleet line white) 503,3ml
 - PT 107 (Cromax Imron fleet line LS black) 3,8ml
 - PT 182 (Cromax Imron fleet line yellow oxide LS) 1,6ml
 - PT 133 (DuPont pigment power tint) 0,5ml
 - EV 310 (Cromax Imron fleet line PUR binder) 712,9ml
- B. Mix colour with hardener EV 313 (Cromax Imron fleet line PUR MS Activator) in ratio 2:1 and finally add a little thinner EV301 (Cromax Imron fleet line industrial multi use thinner) about 2cl. The white colour is from the Imron industry RAL classic swatch with number 9016. Or you can use another adequate colour.
- C. For grey metallic variant order original BMW A52 colour and mix it with thinner in ratio 3:1 and apply on the surface. Then apply a layer of clear lacquer on the paint as follows:
- Mix colourless lacquer VR 1120 (Cromax value clear VOC) with hardener VR 1131 (Cromax value activator) in a ratio of 2:1 and apply to the surface.
- Or you can use another adequate colour.
- For both variants is usually used 150 to 200ml of paint for both legs.

APPROVAL:

This Service Bulletin has been approved by:

TITLE:	Head of Design Organisation	Airworthiness Manager
NAME:	David Bilík	Jan Pejchar
HAND WRITTEN SIGNATURE:		