



CRUISER  
AIRCRAFT

No.: SB-SC-104

DATE: 2024-02-15

PAGE: 1/18

# SERVICE BULLETIN

Czech Aircraft Group s.r.o.  
Na Záhonech 212  
686 04 Kunovice  
Czech Republic  
info@cruiseraircraft.cz

REV.: 1

DATE: 2024-05-13

<b>MODEL AFFECTED:</b>	SportCruiser / PiperSport operating outside EASA rules
<b>SUBJECT:</b>	Installation of engine cooling system with Silent-Hektik F1209v dual circuit thermostatic valve
<b>AIRCRAFT AFFECTED:</b>	All SportCruiser / PiperSport operating outside EASA rules
<b>COMPLIANCE:</b>	According to the owner's decision.

## **DESCRIPTION:**

This Service Bulletin contain instructions for installation water cooling system with Silent - Hektik F1209v dual circuit thermostatic valve on Rotax 912 ULS2 or Rotax 912 S2 engine.

## **AUTHORISATION TO PERFORM:**

Repairman (LS-M) or Mechanic (A&P)

## **MANPOWER:**

8 hours

## **SPECIAL TOOLS:**

Common tools for aircraft maintenance.

## **WEIGHT AND BALANCE:**

Affected

## **ELECTRICAL LOAD DATA:**

N/A

## **PUBLICATIONS AFFECTED:**

Pilot's Operating Manual (POH)

## **MATERIAL AND COSTS:**

All costs to be covered by the aircraft owner / operator.



CRUISER  
AIRCRAFT

No.: SB-SC-104

DATE: 2024-02-15

PAGE: 2/18

# SERVICE BULLETIN

Czech Aircraft Group s.r.o.  
Na Záhonech 212  
686 04 Kunovice  
Czech Republic  
info@cruiseraircraft.cz

REV.: 1

DATE: 2024-05-13

## MATERIAL:

ITEM No.	NOMENCLATURE	DESCRIPTION	QUANTITY
1	3231A303	Cotter Pin AN380-3-3	2 pcs
2	SE0759N	Cooling Tube (Left)	1 pc
3	SE0755N	Cooling Tube (Right)	1 pc
4	SE0756N	Cooling Tube (Top)	1 pc
5	SE0714N	Insulation Blanket	2 pcs
6	3809D009	Thermostatic Valve F1209v	1 pc
7	Use original part	Rotax Overflow Bottle (922327)	1 pc
8	512K2107	Rubber Hose (Black)	1 m
9	512K2204	Silicon Hose (Blue)	0.2 m
10	3431V022	Silicon Hose Elbow 45°	4 pcs
11	3137V002	Silent Block	4 pcs
12	3121X603	Self-locking nut DIN 985-M6-ZB	4 pcs
13	3131X602	Washer DIN 125-6.4-ZB	4 pcs
14	Use original part	Bolt AN3-3A	1 pc
15	3121B654	Self-locking nut AN365-425	1 pc
16	Use original part	Washer AN960-10	1 pc
17	3330A001	Hose Clamp 1/4"-5/8"	2 pcs
18	3330A008	Hose Clamp Torro 25-40/9	12 pc
19	Use original part	Bolt ISO 4017-M10x12-8.8-ZB	2 pc
20	3131Y001	Serrated Washer DIN 6798A-10.5-ZB	2 pc
21	3330A025	Cobra Hose Clamp	1 pc
700	3801A017 <sup>3,4</sup>	Safety Wire 0.32" Stainless Steel	0.5 m
701	512K2101	Hose 6/12mm (black)	0.3 m
702	512K2201	Hose FDK-R 25/32mm (black)	0.5 m
703	3331A006 <sup>4</sup>	Zip Tie CB 360/4.5 Natur	1 pack
704	3331A003 <sup>4</sup>	Zip Tie CB 200/3.6 Natur	1 pack
705	4610A003 <sup>3,4</sup>	Loctite 243	1 pack

<sup>1</sup> without holes, <sup>2</sup> one of these, <sup>3</sup> order in local store, <sup>4</sup> or suitable equivalent

## ENGINE COOLING SYSTEM DESCRIPTION:

For description of cooling system see Maintenance Manual SC-AMM-1-0-00, Ch. 10. This service bulletin describes installation of cooling system with dual circuit thermostatic valve (mount on pump).

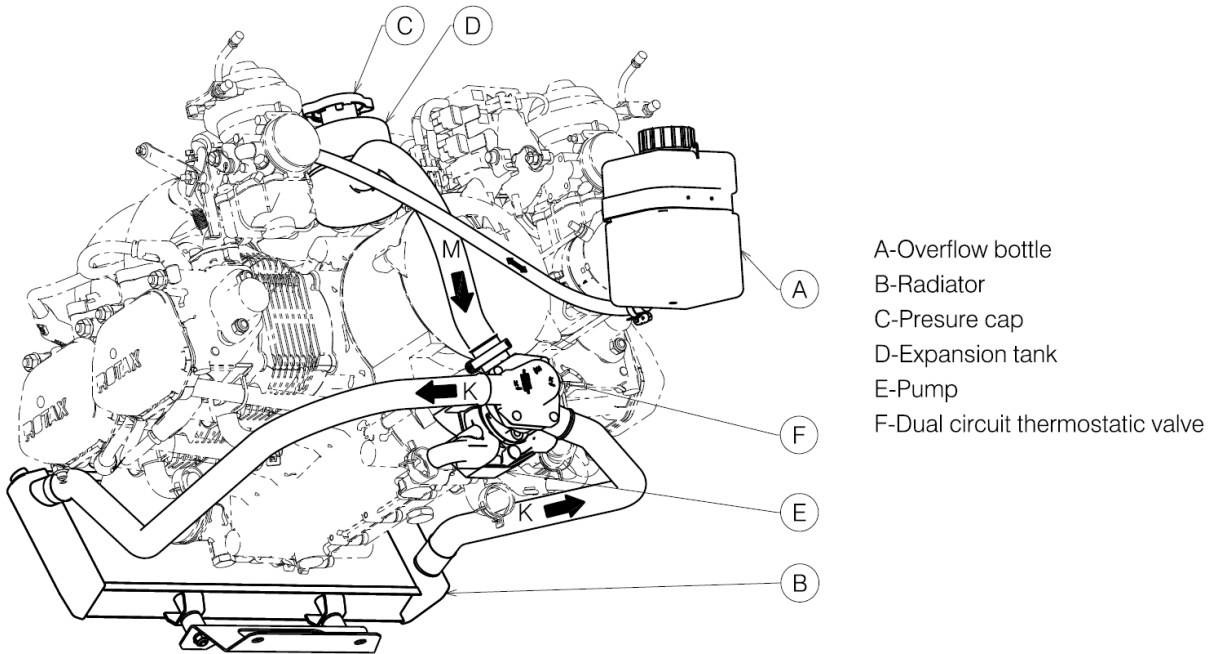


Fig. 1: Principial scheme

### **ACCOMPLISHMENT INSTRUCTIONS:**

**NOTE:** During the implementation of this SB follow AC43-13 and SC-AMM-1-0-00

**NOTE:** This service bulletin doesn't contain information about replacement Rotax original cooling hoses (black hoses of engine cooling system).

#### **Removal:**

- 1) Remove engine cowling. Disconnect positive battery terminal.
- 2) Remove the exhaust tube on the right side of the engine. Other exhaust component can be also removed if needed.
- 3) Put a vessel with capacity of about 5 liters or more under the lowest point of the cooling system (i.e., under radiator outlet tube).
- 4) Remove the insulation blanket. Disconnect the hose from the radiator outlet (the lowest cooling system point). Release the cap of the expansion tank (on top of engine). Drain the coolant into the vessel.
- 5) Optionally the airbox can be removed for easier access to back part of engine.
- 6) Remove rest of old cooling system.

#### **Installation:**

- 7) Replace silent-blocks (item 11) for new one. Use new self-locking nuts (item 12). Replace serrated washers (item 20) under bolts (item 29). In this point, it is not necessary to tighten the nuts and bolts because of further radiator adjustment.
- 8) Remove metal elbow from engine colling water inlet (back side of engine)

**NOTE:** Further accomplishment instructions are supported by drawings and pictures below.



CRUISER  
AIRCRAFT

No.: SB-SC-104

DATE: 2024-02-15

PAGE: 4/18

# SERVICE BULLETIN

Czech Aircraft Group s.r.o.  
Na Záhonech 212  
686 04 Kunovice  
Czech Republic  
info@cruiseraircraft.cz

REV.: 1

DATE: 2024-05-13

- 9) Install thermostatic valve on engine colling water inlet. Use screw provided in valve package. Secure screws by Loctite 243 or by equivalent thread locking glue.
- 10) Install back the airbox (if it was removed).
- 11) Install overflow hose (item 8) between Rotax overflow plastic bottle (item 7) and expansion tank. Use hose clam (item 17) for securing overflow hose to plastic bottle. Use Cobra hose clam (item 21) for securing overflow hose to expansion tank. Replace self-locking nut (item 15) on bottle holder if needed.
- 12) Install back all exhaust components. Secure exhaust spring with wire (item 700).
- 13) Install tubes (item 2, 3, 4). Use blue silicon hoses and elbows as a connecting element (item 9, 10). Each joint has to be secured by hose clamp (item 18). Contact area can be lubricated with drop of fresh coolant liquid for easier slip-on hose on the tubes. Make sure that tubes and hoses are sufficient distance from engine, engine component and engine mount. As a sufficient distance is considered 10 mm. Minimum distance is 5 mm.
- 14) Set final position of the radiator. Tighten self-locking nuts (item 12) and secure castle nuts on bottom side of engine mount by cotter pins (item 1).
- 15) Install heat shield blankets to input and output radiator hose (near exhaust elbows). Heat shield blankets are tied up with safety wire (item 700).
- 16) Prevent the tubes from moving by using zip ties (item 703 and 704) and attach the tubes to the engine. Avoid direct contact zip ties with hot metal parts using piece hose (item 702) or rest of blue hose (item 9, 10) as a shield. One wall of hose can be axially cut for easier slip on.  
Piece of hose (item 702) or rest of blue hose (item 9, 10) use as a protection for tube (item 2) against direct contact with engine mount.  
Use piece of hose (item 701) and zip tie (item 703, 704) to simple delimiter bumper.
- 17) Prevent the overflow hose from moving by using Zip Ties (item 703, 704) and attach the overflow hose to the other hoses (fuel) and airbox.
- 18) Fill the engine cooling system with coolant. See Maintenance Manual SC-MM-1-0-00, Ch. 10 for proper coolant type. Coolant capacity is about 3.5 liters.
- 19) Install battery and engine cowling.
- 20) Perform engine test.
- 21) Remove engine cowling. Disconnect positive battery terminal.
  - a. Check cooling system for tightness.
  - b. Check mechanical stiffens of the system.
  - c. Check tolerances and clearance between engine and engine component.
  - d. Check any sign of mechanical damage or abrasion.
  - e. Check volume of coolant. Replenish when needed.
- 22) Install battery and engine cowling.
- 23) Weigh the aircraft and calculate the center of gravity (C.G.). Write data to the POH. Contact aircraft manufacturer, if the empty C.G. value exceed the permissible tolerance.
- 24) Restore aircraft to the airworthy condition.
- 25) Update the aircraft maintenance record to reflect the compliance with this service bulletin.

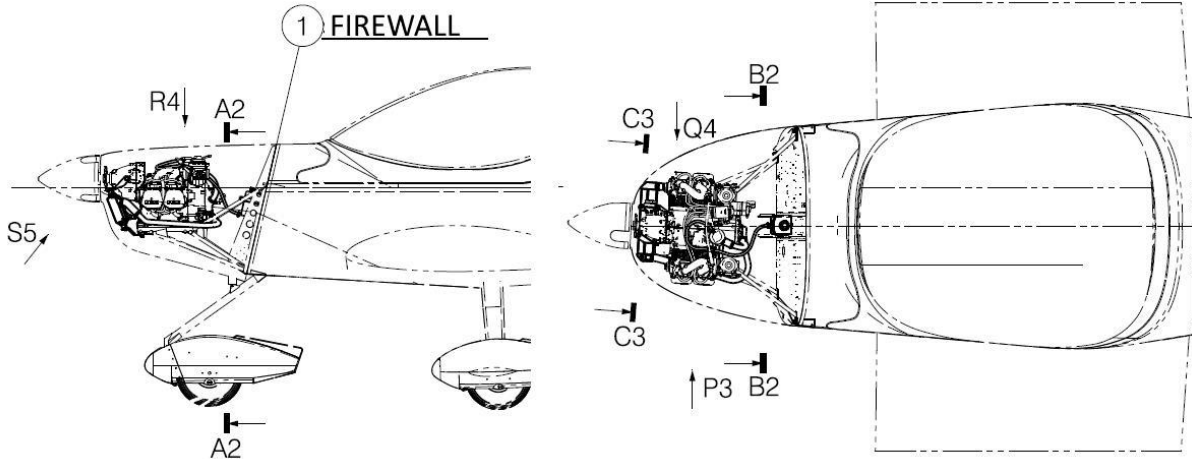
**PICTURES FOR ACCOMPLISHMENT INSTRUCTIONS:**


Fig. 2: Views and sections definition

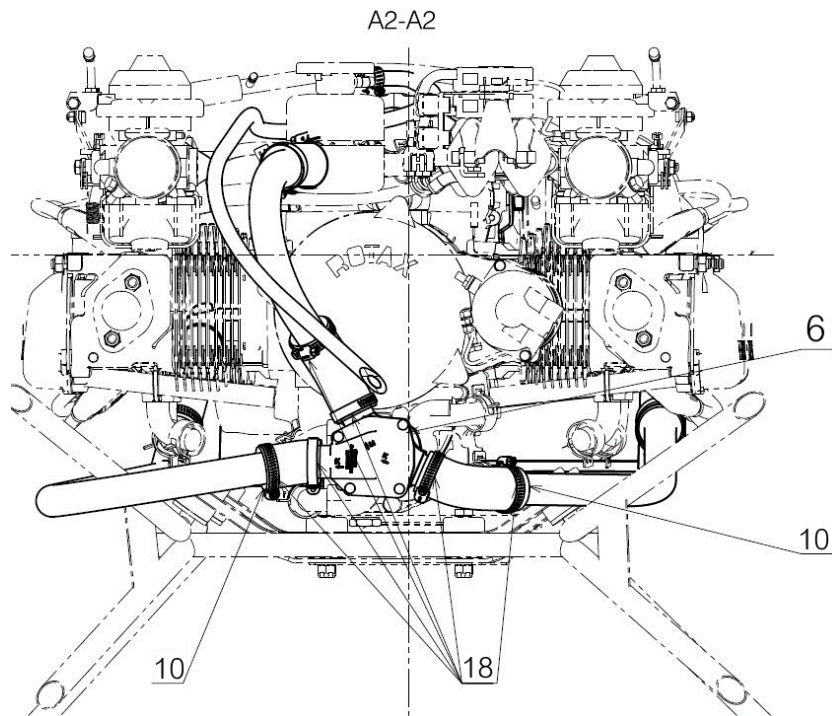


Fig. 3: Section A2-A2

# SERVICE BULLETIN

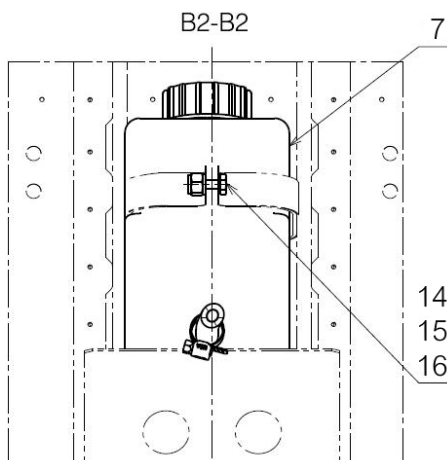


Fig. 4: Section B2-B2

## C3-C3

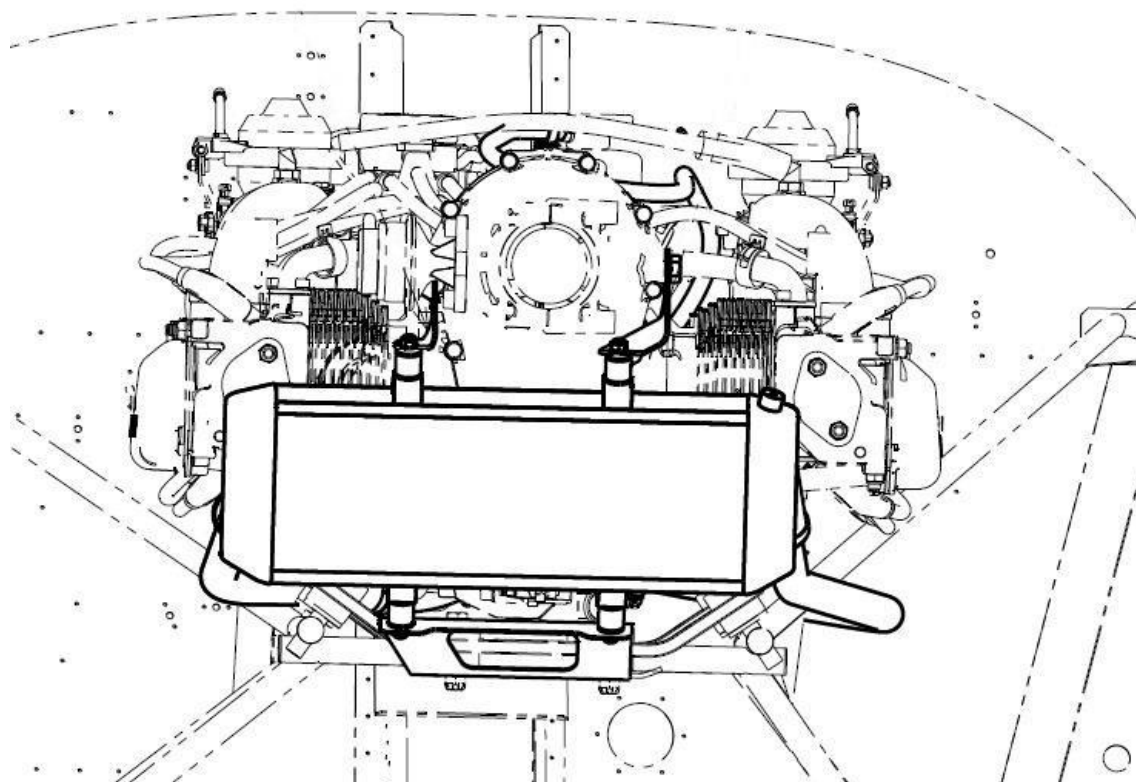


Fig. 5: Section C3-C3



CRUISER  
AIRCRAFT

No.: SB-SC-104

DATE: 2024-02-15

PAGE: 7/18

# SERVICE BULLETIN

Czech Aircraft Group s.r.o.

Na Záhonech 212

686 04 Kunovice

Czech Republic

info@cruiseraircraft.cz

REV.: 1

DATE: 2024-05-13

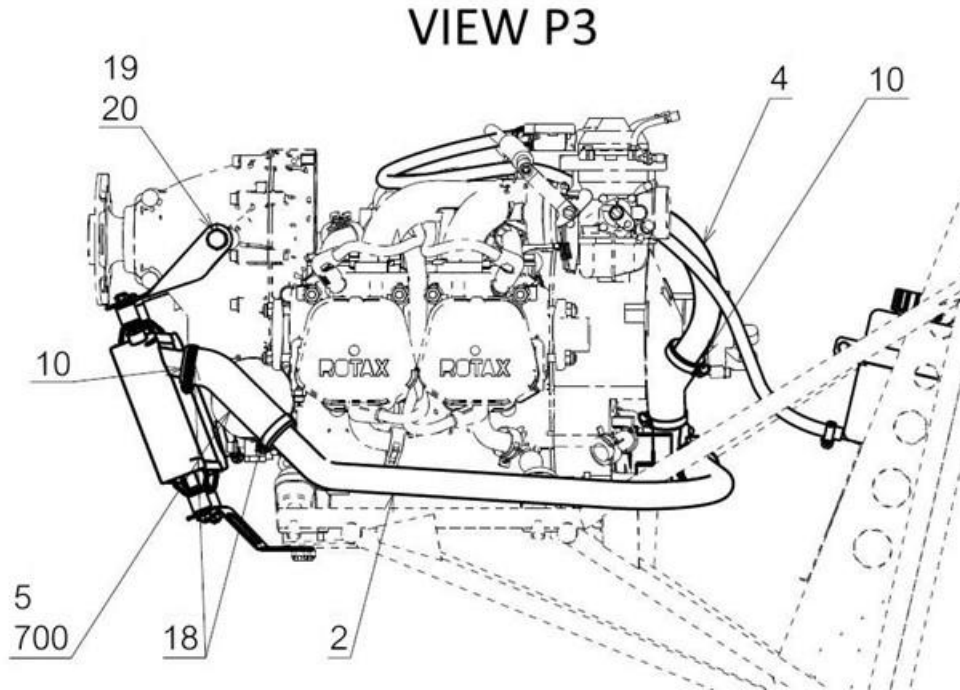


Fig. 6: View P3

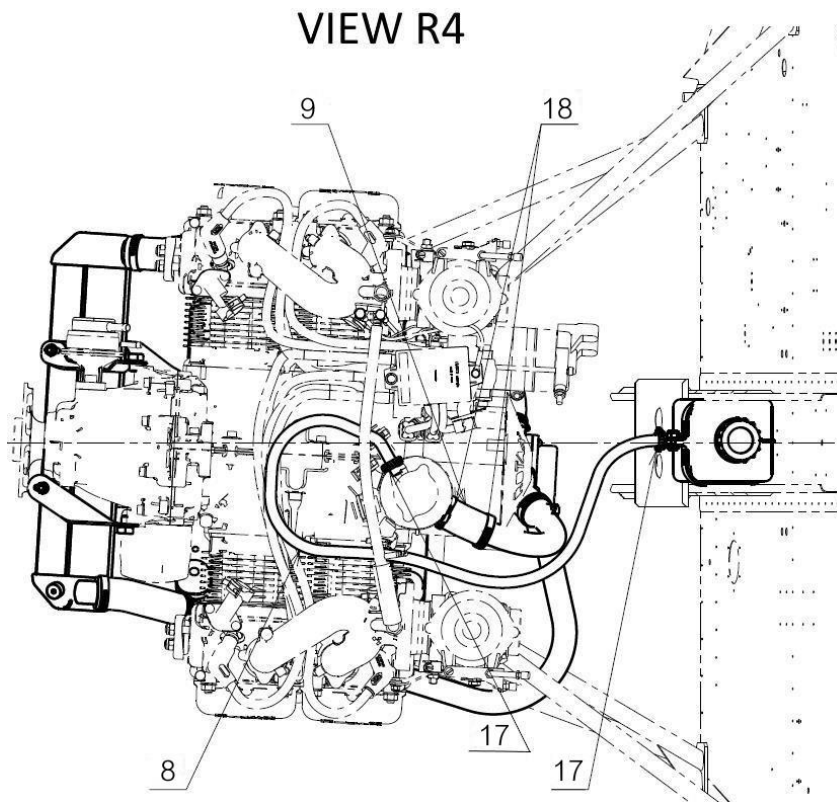


Fig. 7: View R4

VIEW S5

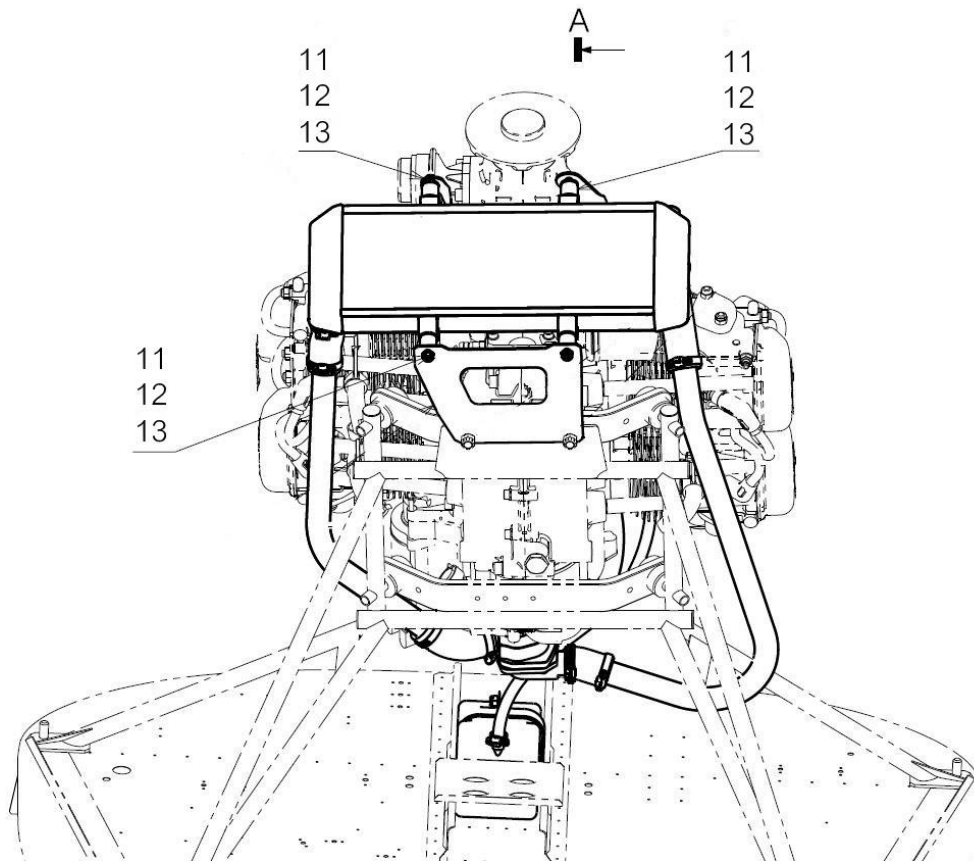


Fig. 8: Section S 5

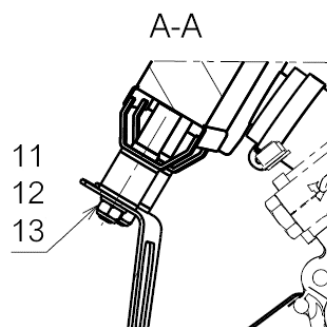


Fig. 9: Section A-A



# SERVICE BULLETIN

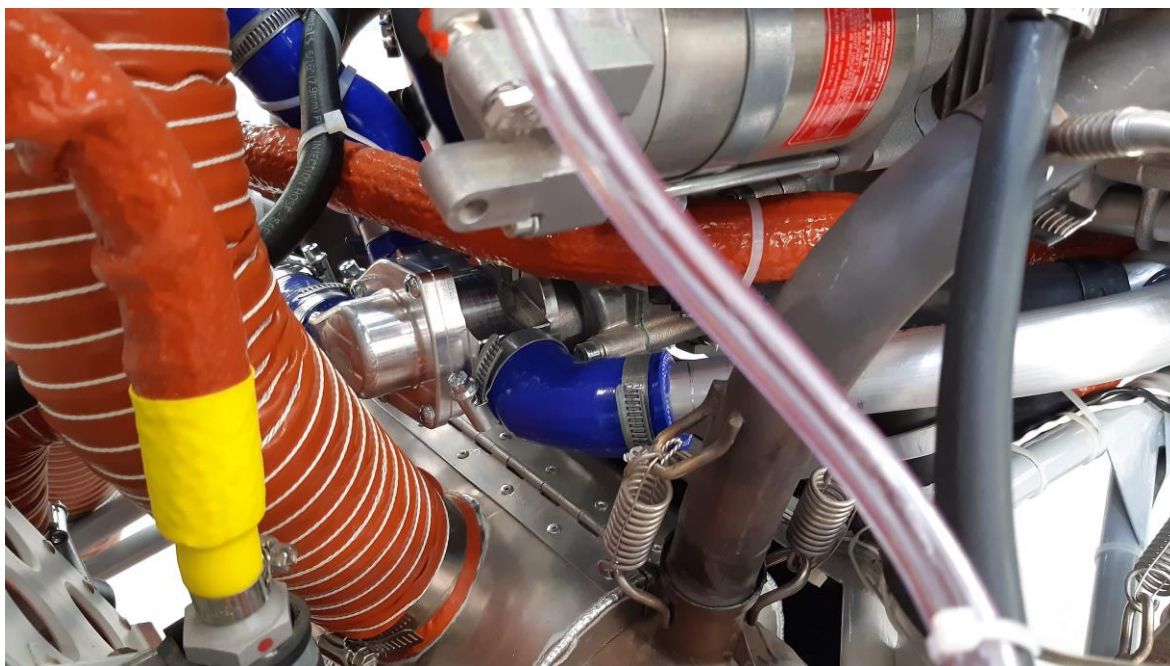


Fig. 10: Thermostatic valve

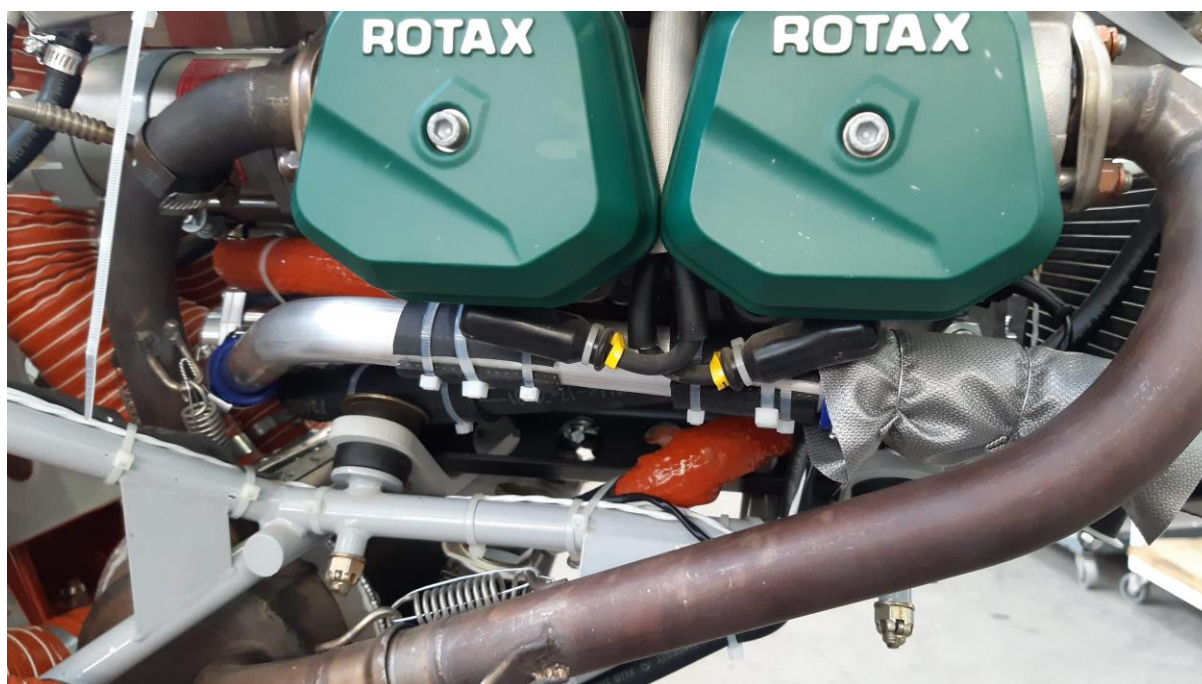


Fig. 11: Right tube

# SERVICE BULLETIN

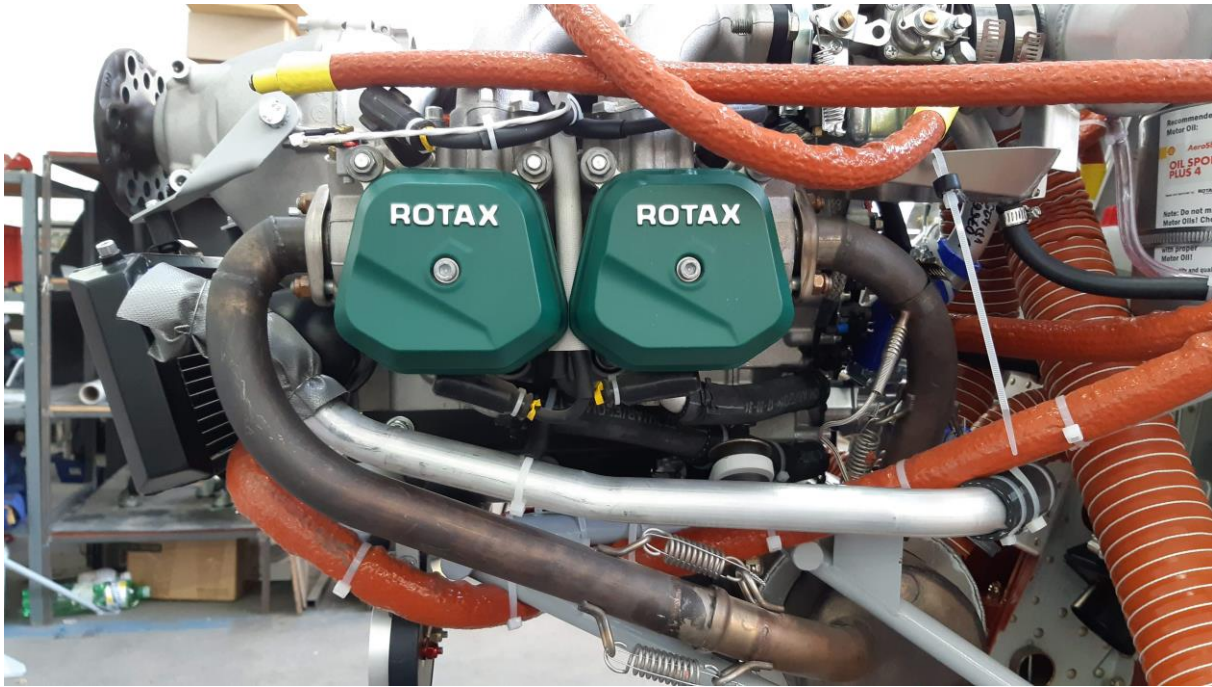


Fig. 12: Left tube

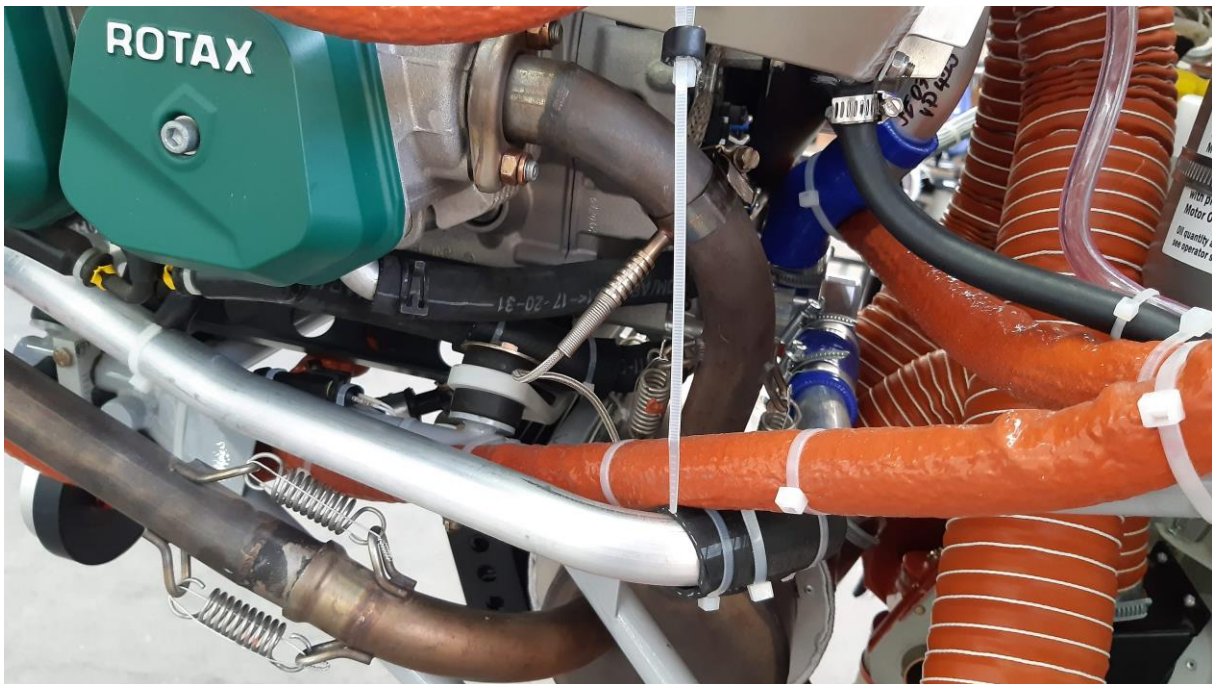


Fig. 13: Left tube

# SERVICE BULLETIN

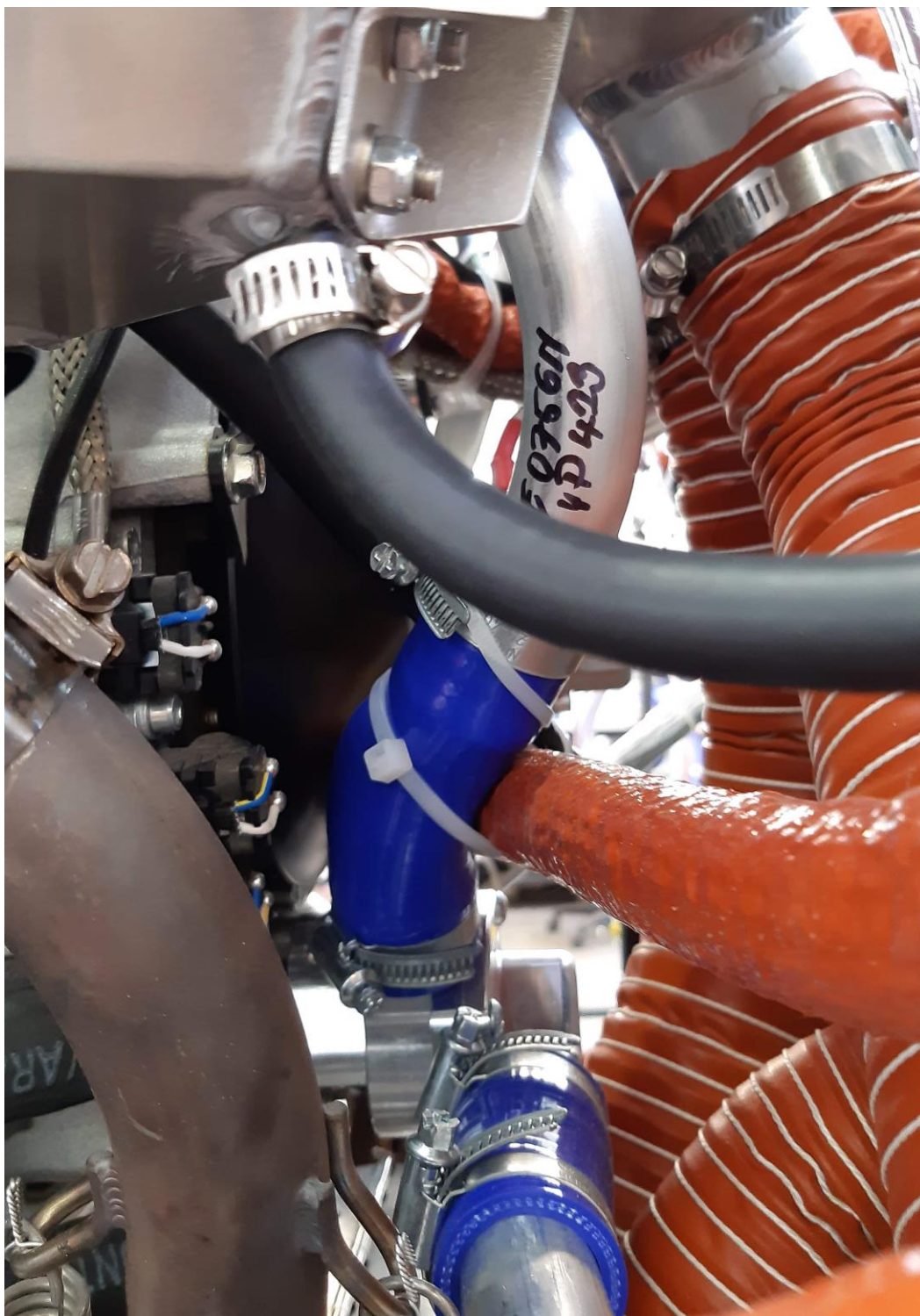


Fig. 14: Top tube



CRUISER  
AIRCRAFT

No.: SB-SC-104

DATE: 2024-02-15

PAGE: 12/18

# SERVICE BULLETIN

Czech Aircraft Group s.r.o.

Na Záhonech 212

686 04 Kunovice

Czech Republic

info@cruiseraircraft.cz

REV.: 1

DATE: 2024-05-13

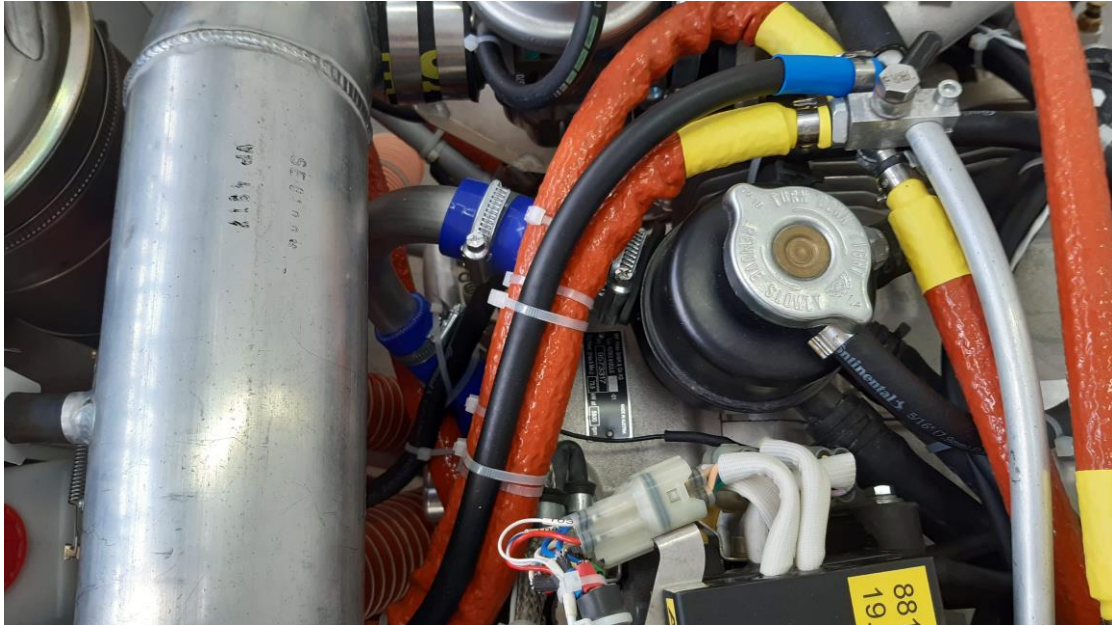


Fig. 15: Top tube and expansion tank

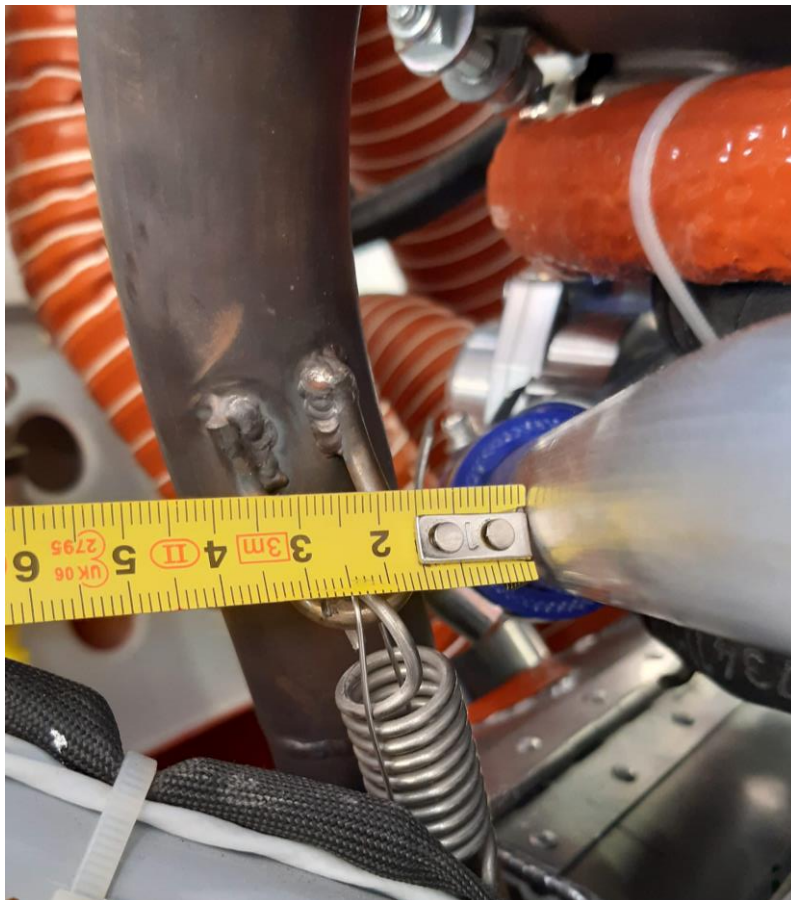


Fig. 16: Typical distance between right tube and right rear exhaust.



CRUISER  
AIRCRAFT

No.: SB-SC-104

DATE: 2024-02-15

PAGE: 13/18

# SERVICE BULLETIN

Czech Aircraft Group s.r.o.

Na Záhonech 212

686 04 Kunovice

Czech Republic

info@cruiseraircraft.cz

REV.: 1

DATE: 2024-05-13



Fig. 17: Typical distance between right front exhaust and radiator

# SERVICE BULLETIN



Fig. 18: Typical distance between right tube and right front exhaust



CRUISER  
AIRCRAFT

No.: SB-SC-104

DATE: 2024-02-15

PAGE: 15/18

# SERVICE BULLETIN

Czech Aircraft Group s.r.o.

Na Záhonech 212

686 04 Kunovice

Czech Republic

info@cruiseraircraft.cz

REV.: 1

DATE: 2024-05-13



Fig. 19: Typical distance between left tube and left front exhaust.

# SERVICE BULLETIN



Fig. 20: Typical distance between left tube and left front exhaust.



# SERVICE BULLETIN

**No.:** SB-SC-104

**DATE:** 2024-02-15

**PAGE:** 17/18

**REV.:** 1

**DATE:** 2024-05-13

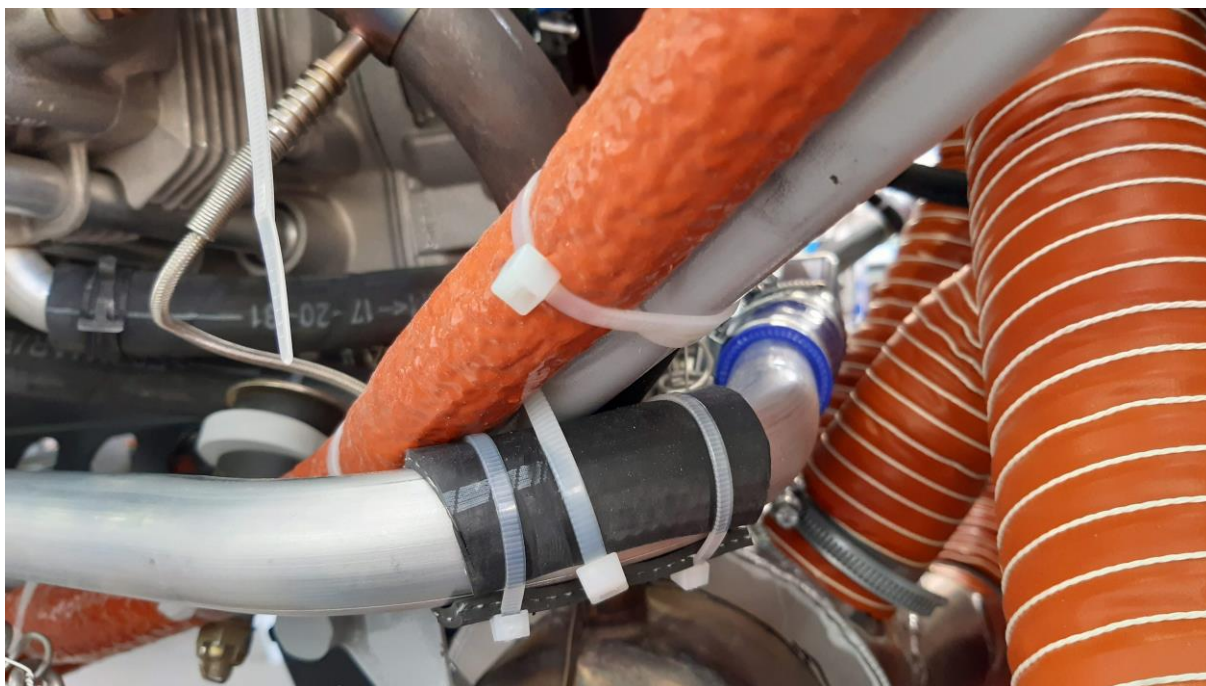


Fig. 21: Detail view of left tube and engine mount.

**APPROVAL:**

This Service Bulletin has been approved by:

<b>TITLE:</b>	Head of Design Organisation	Airworthiness Manager
<b>NAME:</b>	David Bilík	Jan Pejchar
<b>HAND WRITTEN SIGNATURE:</b>		



CRUISER  
AIRCRAFT

**No.:** SB-SC-104

**DATE:** 2024-02-15

**PAGE:** 18/18

# SERVICE BULLETIN

Czech Aircraft Group s.r.o.

Na Záhonech 212

686 04 Kunovice

Czech Republic

info@cruiseraircraft.cz

**REV.:** 1

**DATE:** 2024-05-13

INTENTIONALLY LEFT BLANK